

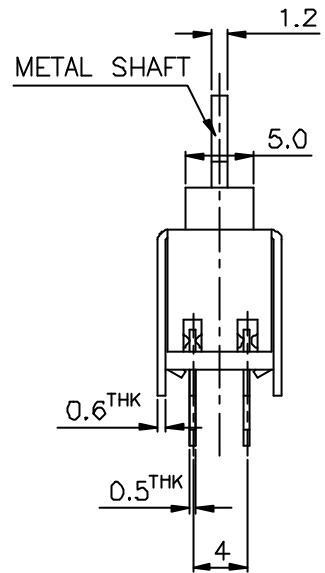

SCHEMATIC

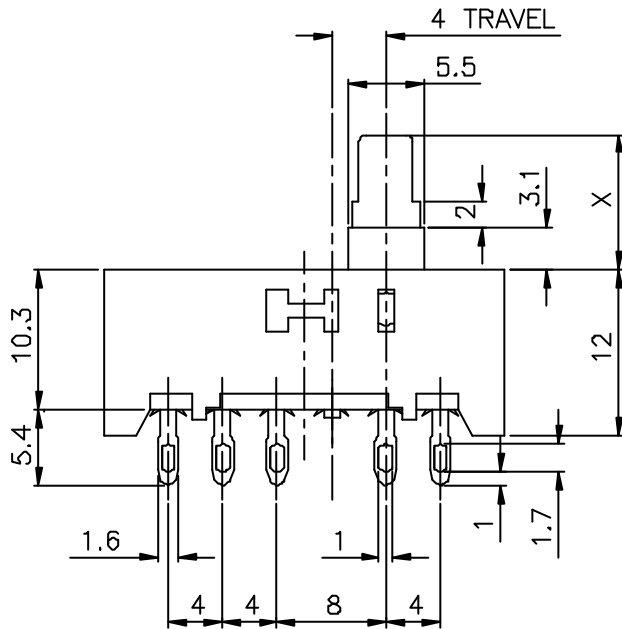

X=

ISSUED	SPECIFICATION (INITIAL)	TITLE: SLIDE SWITCH 2P4T			
	RATING: DC 50V 0.5A	MODEL NO: SS-24H04-M			
	CONTACT RESISTANCE: MAX. 30mΩ	UNIT: m m	DWN	LIU	18.09.09
	INSULATION RESISTANCE 500MΩ AT 500V DC	SCALE: 2 : 1	CHK'D		
	WITHSTAND VOLTAGE: AC 500V FOR 1 MIN	TOLERANCE ±0.2	APPD		
	OPERATION FORCE: 350 ± 200g				
	SWITCHING LIFE: 10000 Cycles(6-10c/m loading)				
BY:	 广东科斯达电子科技有限公司 GUANG DONG KE SI DA ELECTRONIC TECHNOLOGY CO., LTD.	DRWG NO:		REV:	
DATE:		A90490-00		A	