

SCHEMATIC

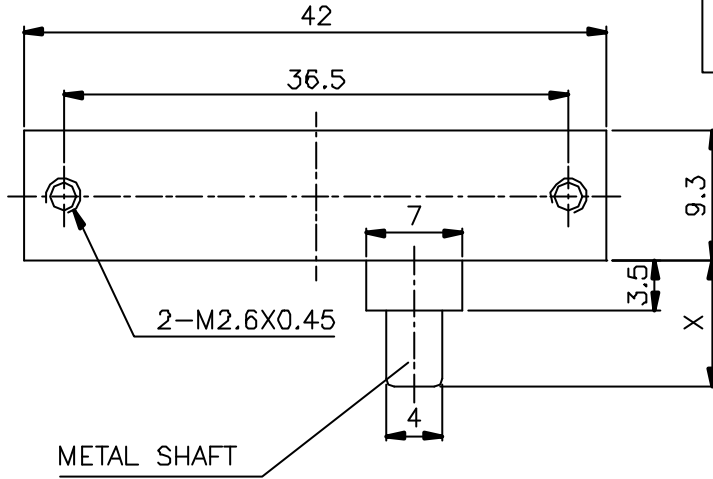

METAL SHAFT

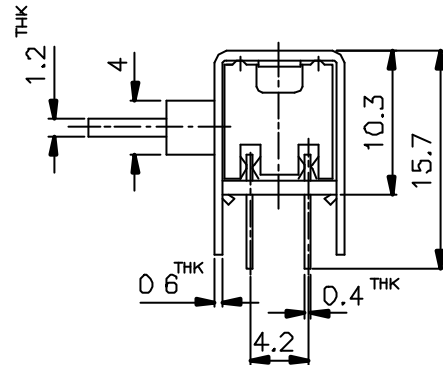
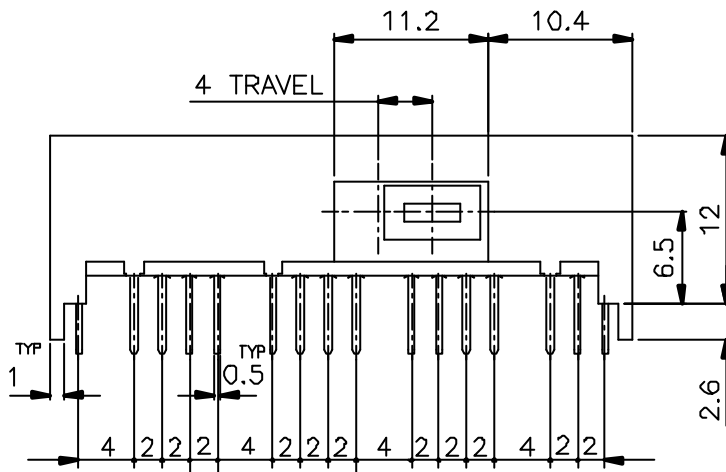

X=

ISSUED	SPECIFICATION (INITIAL)	TITLE: SIDE KNOB SLIDE SWITCH 8P2T		
BY: DATE:	RATING: DC 50V 0.5A	MODEL NO: SK-82H01-M		
	CONTACT RESISTANCE: Not more than 30mΩ	UNIT: mm	DWN	
	INSULATION RESISTANCE: 500MΩ at 500V DC	SCALE: 2 : 1	CHK'D	
	WITHSTAND VOLTAGE: AC 500V for 1 min	TOLERANCE: ±0.2	APPD.	
	OPERATION FORCE: 200±100g	DRWG NO: 890015-00		
	SWITCHING LIFE: 10000 Cycles (6-10c/m loading)	GUANG DONG KE SI DA ELECTRONIC TECHNOLOGY CO., LTD.		



广东科斯达电子科技有限公司
GUANG DONG KE SI DA ELECTRONIC TECHNOLOGY CO., LTD.