

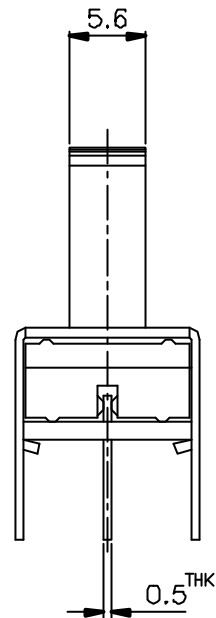

NON-SHORTING
SCHEMATIC

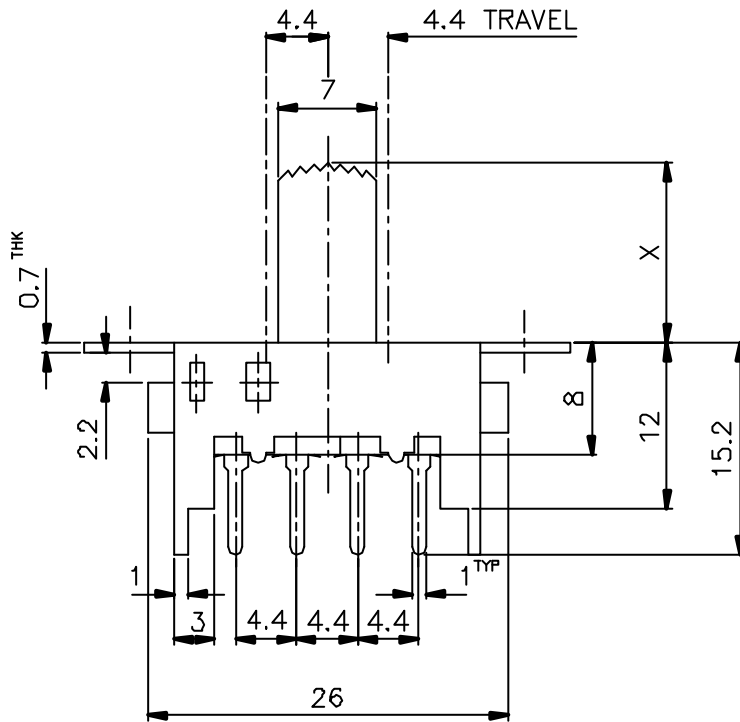

X =

| | | | | |
|--------|---|--------------------------|-------|--|
| ISSUED | SPECIFICATION (INITIAL) | TITLE: SLIDE SWITCH 1P3T | | |
| | RATING: DC 50V 0.5A | MODEL NO: SS-13105-G | | |
| | CONTACT RESISTANCE: Not more than 30mΩ | UNIT: mm | DWN | |
| | INSULATION RESISTANCE: 500MΩ at 500V DC | SCALE: 2 : 1 | CHK'D | |
| | WITHSTAND VOLTAGE: AC 500V for 1 min | TOLERANCE: ±0.20 | APPD. | |
| | OPERATION FORCE: 350±200g | | | |
| | SWITCHING LIFE: 10000 Cycles (6-10c/m loading) | | | |
| BY: |  广东科斯达电子科技有限公司 GUANG DONG KE SI DA ELECTRONIC TECHNOLOGY CO., LTD. | DRWG NO: | | |
| DATE: | | B 800963-00 | | |