

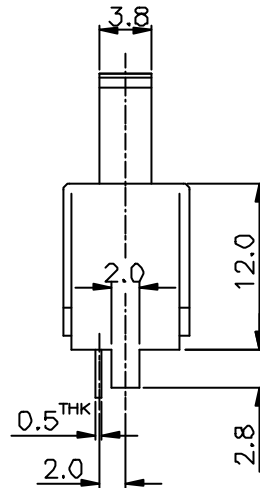

SCHEMATIC

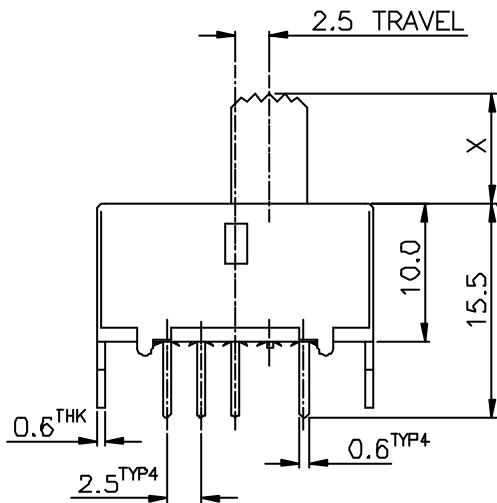
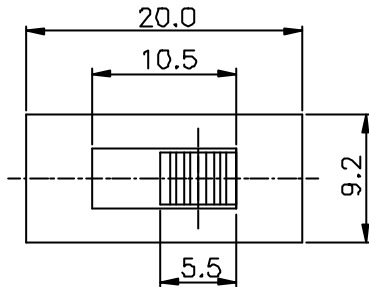

X=

ISSUED	SPECIFICATION (INITIAL)	TITLE: SLIDE SWITCH 1P3T							
	RATING: DC 50V 0.5A	MODEL NO: SS-13E01-G							
	CONTACT RESISTANCE: MAX. 30mΩ	UNIT	m	m	DWN	S	C	C	25/5-82
	INSULATION RESISTANCE: 500MΩ at 500V DC	SCALE: 2 : 1		CHK'D					
	WITHSTAND VOLTAGE: AC 500V FOR 1 MIN	TOLERANCE: ±0.2		APPD.					
	OPERATION FORCE: 350±200g	DRWG NO: B 800316-00							
	SWITCHING LIFE: 10000 Cycles(6-10c/m loading)								
BY:	 广东科斯达电子科技有限公司 GUANG DONG KE SI DA ELECTRONIC TECHNOLOGY CO., LTD.								
DATE:									