

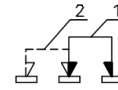

KSD

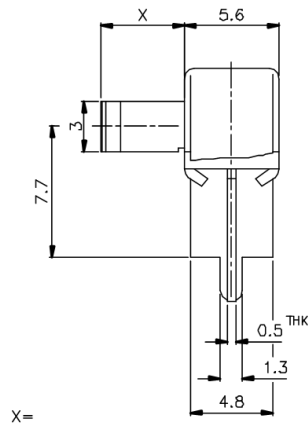

SCHEMATIC

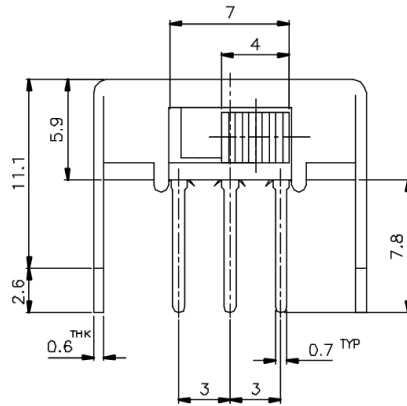
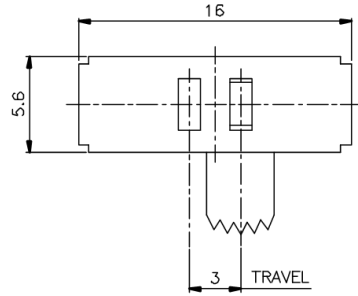

X=

ISSUED	SPECIFICATION (INITIAL)	TITLE: SLIDE SWITCH 1P2T
	RATING: DC 30V 0.3A	MODEL NO: SK-12F19-G
	CONTACT RESISTANCE: Not more than 30mΩ	UNIT: m m DWN
	INSULATION RESISTANCE: 500MΩ at 500V DC	SCALE: 4 : 1 CHK'D
	WITHSTAND VOLTAGE: AC 500V for 1 min	TOLERANCE: ±0.2 APPD.
	OPERATION FORCE: 250 ± 150g	
	SWITCHING LIFE: 10000 cycles(6-10c/m loading)	
BY:	 广东科斯达电子科技有限公司 GUANG DONG KE SI DA ELECTRONIC TECHNOLOGY CO., LTD.	DRWG NO:
DATE:		900046-00