

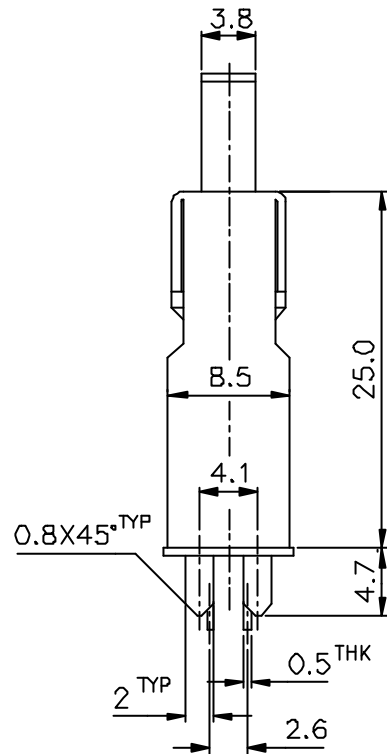

SCHEMATIC

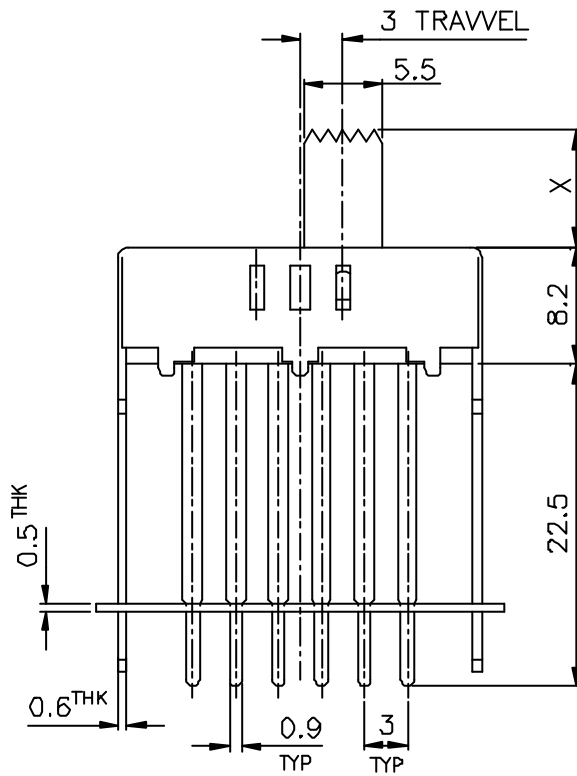

X =

ISSUED	SPECIFICATION (INITIAL)	TITLE: SLIDE SWITCH 2P3T			
	RATING: DC 50V 0.5A	MODEL NO: SS-23F27-G(A)			
	CONTACT RESISTANCE: Not more than 30mΩ	UNIT: m m	DWN	XZK	14 09 D9
	INSULATION RESISTANCE: 500MΩ at 500V DC	SCALE: 2 : 1			
	WITHSTAND VOLTAGE: AC 500V for 1 min	TOLERANCE: ±0.2			
	OPERATION FORCE: 250 ± 150g	APPD.			
	SWITCHING LIFE: 10000 Cycles(6-10c/m loading)				
BY.	 广东科斯达电子科技有限公司 GUANG DONG KE SI DA ELECTRONIC TECHNOLOGY CO., LTD.	DRWG NO:			REV
DATE		A90454-00			A