

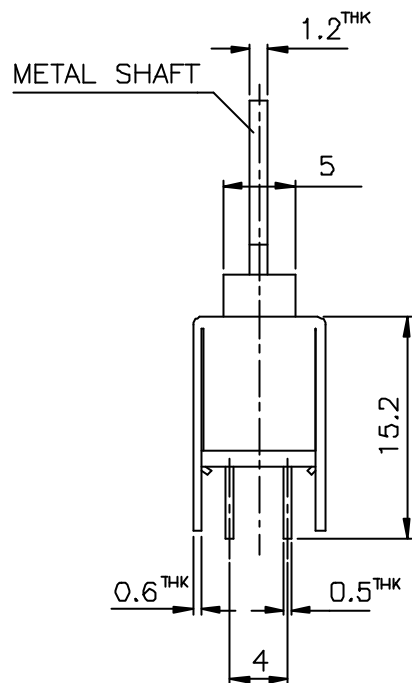

SCHEMATIC

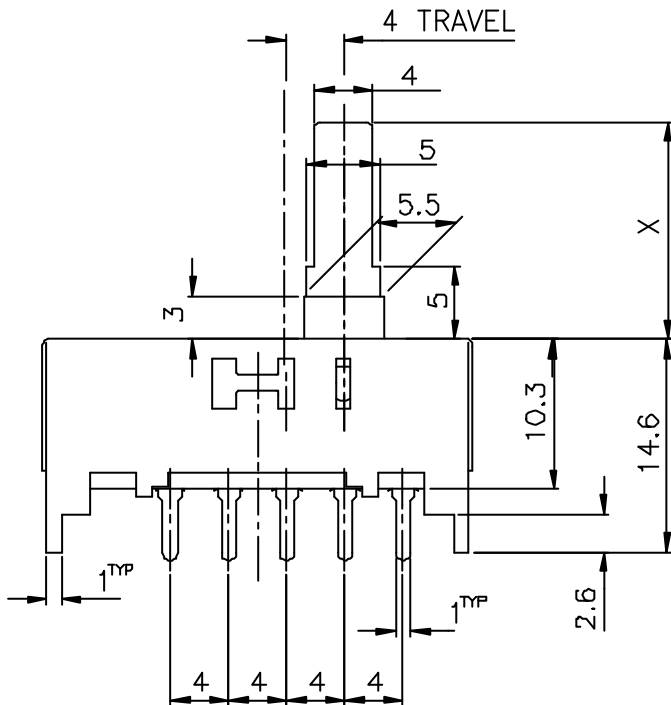

X=

ISSUED	SPECIFICATION (INITIAL)	TITLE: SLIDE SWITCH 2P4T			
	RATING: DC 50V 0.5A	MODEL NO: SS-24H09-M			
	CONTACT RESISTANCE: Not more than 30mΩ	UNIT: m m	DWN	XZK	15.9.09
	INSULATION RESISTANCE: 500MΩ at 500V DC	SCALE: 2 : 1	CHK'D		
	WITHSTAND VOLTAGE: AC 500V for 1 min	TOLERANCE: ±0.2	APPD		
	OPERATION FORCE: 300±200g				
	SWITCHING LIFE 10000 Cycles(6-10c/m loading)				
BY:	 广东科斯达电子科技有限公司 GUANG DONG KE SI DA ELECTRONIC TECHNOLOGY CO., LTD.	DRWG NO:		REV:	
DATE:		A90465-00		A	