

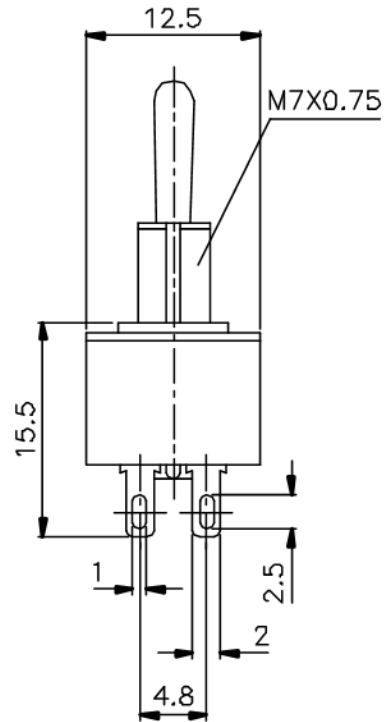

(NON-SHORTING)  
SCHEMATIC

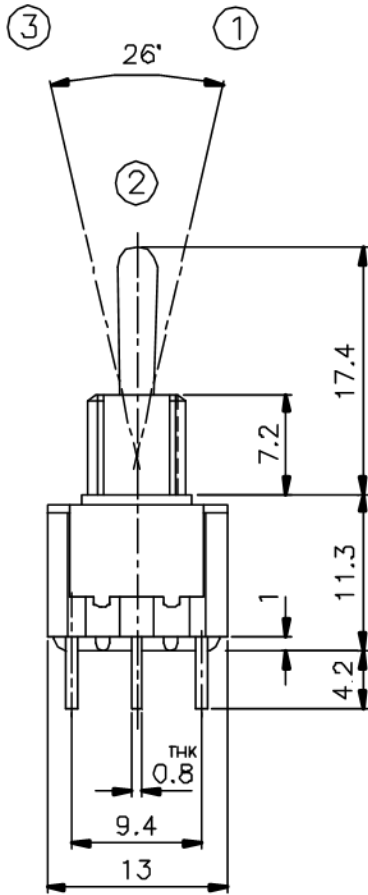

ISSUED	SPECIFICATION (INITIAL)	TITLE: TOGGLE SWITCH 2P3T		
	RATING: AC 125V 3A	MODEL NO: WT-23101-T(P1)17.4		
	CONTACT RESISTANCE: Not more than 30m Ω	UNIT: m	m	DWN
	INSULATION RESISTANCE: 100M OHM AT 500V DC	SCALE: 2 : 1	CHK'D	
	WITHSTAND VOLTAGE: AC 1000V FOR 1 MIN	TOLERANCE: ±0.20	APPD.	
	OPERATION FORCE: 300 ± 150 GRAMS			
	SWITCHING LIFE: 10000 Cycles (6-10c/m loading)			
BY:	 <b>广东科斯达电子科技有限公司</b> GUANG DONG KE SI DA ELECTRONIC TECHNOLOGY CO., LTD.	DRWG NO:		
DATE:		890090-00		