

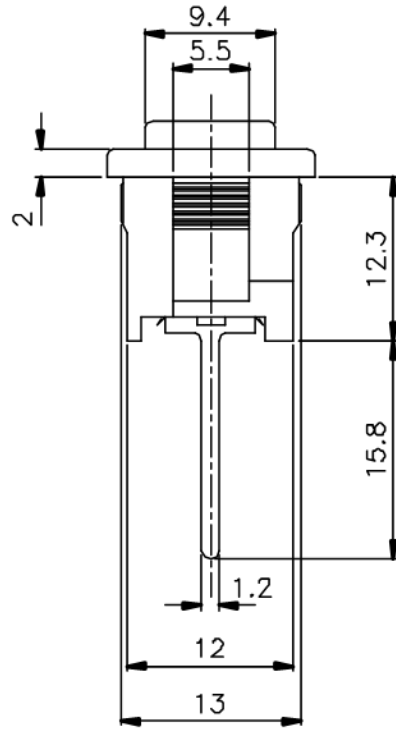

NON-SHORTING  
SCHEMATIC

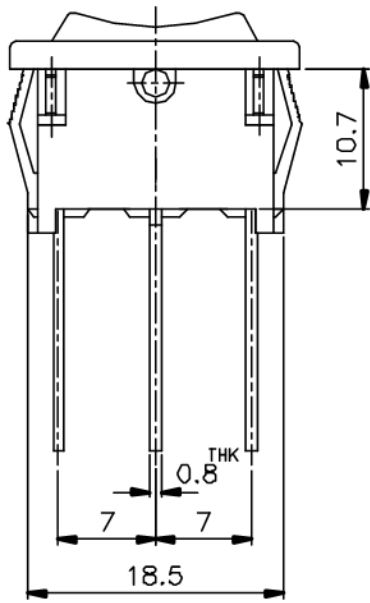

Panel Cut-out Dimensions

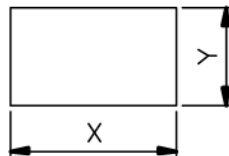

Rating : UL: U11  11A 125VAC  
5.5A 250VAC

Panel Thickness (mm/inch)	DIM X <sup>+0.1</sup> (mm/inch)	DIM Y <sup>±0.1</sup> (mm/inch)
0.5~1.2 (.02~.05)	19.4 (.764)	13.1 (.516)
1.2~2.0 (.05~.08)	19.7 (.775)	
2.0~3.0 (.08~.12)	20.0 (.787)	

ISSUED	SPECIFICATION (INITIAL)	TITLE: ROCKER SWITCH 1P3T		
BY: DATE:	RATING: AC 125V 11A; 250V 5.5A	MODEL NO: U11WR-13N03-R1(00)		
	CONTACT RESISTANCE: MAX. 30mΩ	UNIT: mm	DWN	
	INSULATION RESISTANCE: 500MΩ at 500V DC	SCALE: 2 : 1	CHK'D	
	WITHSTAND VOLTAGE: AC 1000V for 1 min	TOLERANCE: ±0.2	APPD.	
	OPERATION FORCE: 500±300g	DRWG NO: 980551-02		
	SWITCHING LIFE: 10000Cycles(6-10c/m loading)			
 <b>广东科斯达电子科技有限公司</b> GUANG DONG KE SI DA ELECTRONIC TECHNOLOGY CO., LTD.				