

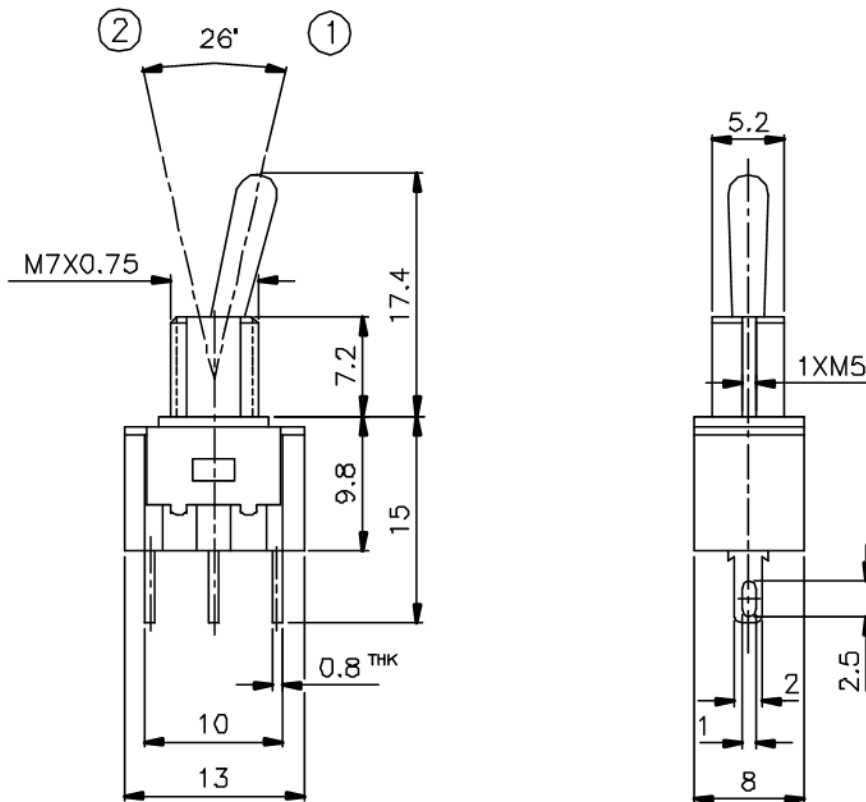

NON-SHORTING
SCHEMATIC



MARKED WITH AC 125V 3A, UL & C-UL LOGO.

ISSUED	SPECIFICATION (INITIAL)	TITLE: TOGGLE SWITCH 1P2T		
	RATING: AC 125V 6A	MODEL NO: CL03-TS12I01-T(P1)17.4		
	CONTACT RESISTANCE: NOT MORE THAN 30mΩ	UNIT:	DWN	
	INSULATION RESISTANCE: 500MΩ AT 500V DC	SCALE:	CHK'D	
	WITHSTAND VOLTAGE: AC 1000V FOR 1 MIN	TOLERANCE:	APPD.	
	OPERATION FORCE: 300±150g			
	SWITCHING LIFE: 10000 Cycles(6-10c/m loading)			
BY:	 广东科斯达电子科技有限公司 GUANG DONG KE SI DA ELECTRONIC TECHNOLOGY CO., LTD.			
DATE:				