

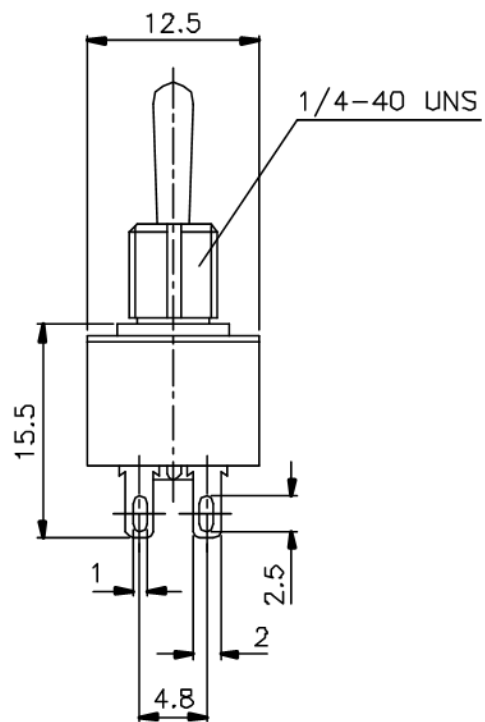

(Non-Shorting)  
SCHEMATIC

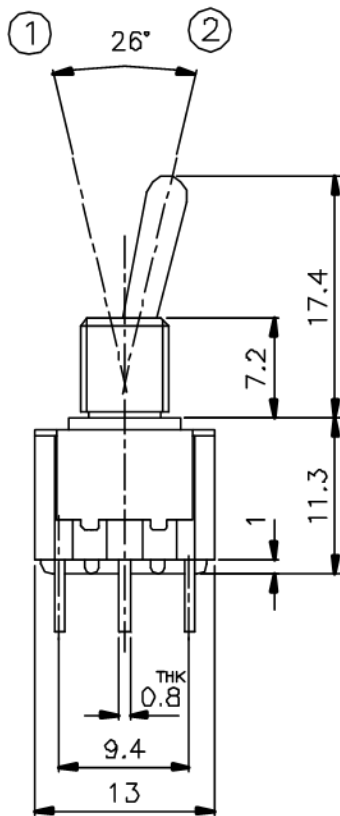

1/4" WASHER  
(Quantity 2 pieces)



1/4"-40 UNS NUT  
(Quantity 2 pieces)

ISSUED	SPECIFICATION (INITIAL)	TITLE: TOGGLE SWITCH 2P2T		
	RATING: AC 125V 3A	MODEL NO: WT-22103-T(P1)		
	CONTACT RESISTANCE: Not more than 30mΩ	UNIT: mm	DWN	
	INSULATION RESISTANCE: 100MΩ at 500V DC	SCALE: 2 : 1	CHK'D	
	WITHSTAND VOLTAGE: AC 1000V for 1 min	TOLERANCE: ±0.2	APPD.	
	OPERATION FORCE: 300 ± 150g			
	SWITCHING LIFE: 10000 Cycles(6-10c/m unloading)			
BY:	 <b>广东科斯达电子科技有限公司</b> GUANG DONG KE SI DA ELECTRONIC TECHNOLOGY CO., LTD.	DRWG NO:		
DATE:		990017-00		