

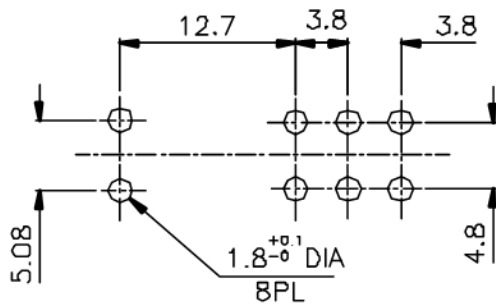

NON-SHORTING
SCHEMATIC

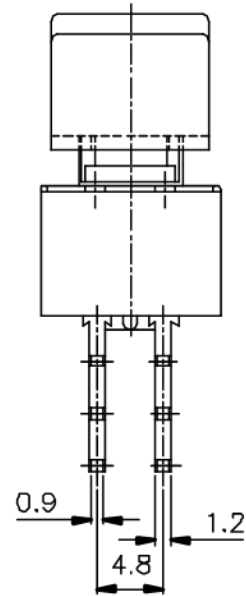
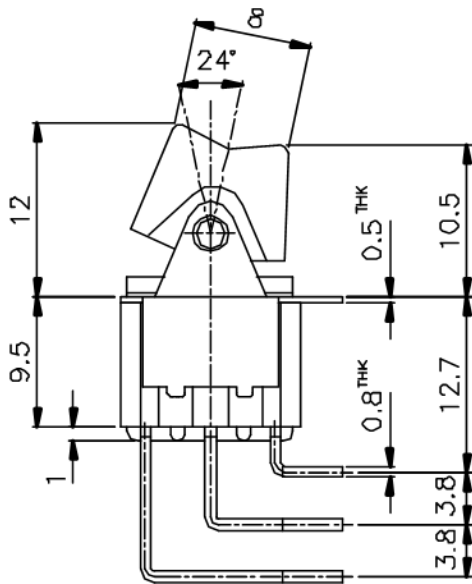

PRINTED CIRCUIT PANEL LAYOUT

ISSUED	SPECIFICATION (INITIAL)	TITLE: ROCKER SWITCH 2P2T		
	RATING: AC 125V 3A	MODEL NO: WR-22101-R3(00)		
	CONTACT RESISTANCE: Not more than 30mΩ	UNIT: mm	DWN	
	INSULATION RESISTANCE: 500MΩ at 500V DC	SCALE: 2 : 1	CHK'D	
	WITHSTAND VOLTAGE: AC 1000V for 1 min	TOLERANCE: ±0.2	APPD.	
	OPERATION FORCE: 700±300g			
	SWITCHING LIFE: 10000 Cycles(6-10c/m unloading)			
BY:	 广东科斯达电子科技有限公司 GUANG DONG KE SI DA ELECTRONIC TECHNOLOGY CO., LTD.	DRWG NO:		
DATE:		980502-00		