

SPRING RETURN

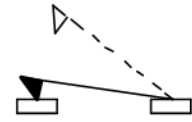

NC
NON-SHORTING
SCHEMATIC

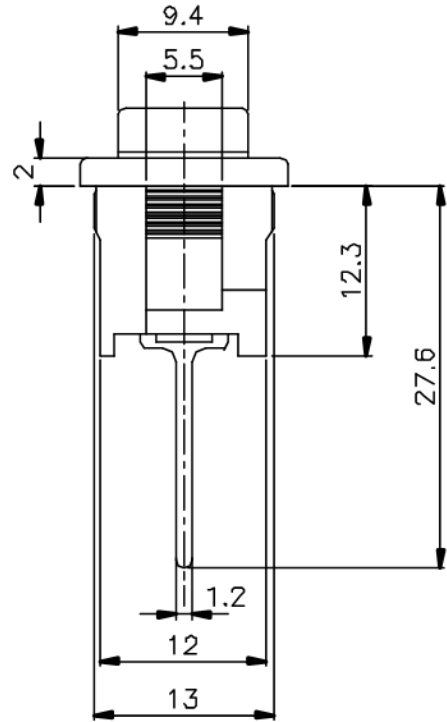
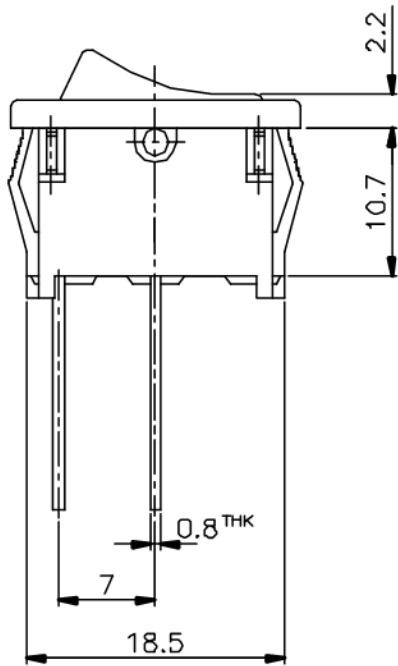

Panel Cut-out Dimensions

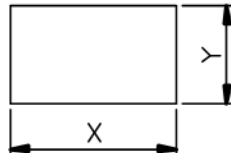

Rating : UL: U11 11A 125VAC
5.5A 250VAC

VDE: U11E4 4A 250V~

| Panel Thickness (mm/inch) | DIM X ⁺⁰ _{-0.1} (mm/inch) | DIM Y ^{+0.1} (mm/inch) |
|------------------------------|--|------------------------------------|
| 0.5~1.2 (.02~.047) | 19.4 (.764) | 13.1 (.518) |
| 1.2~2.0 (.047~.08) | 19.7 (.775) | |
| 2.0~3.0 (.08~.118) | 20.0 (.787) | |

| | | | | |
|--------|---|---------------------------------|-------|--|
| ISSUED | SPECIFICATION (INITIAL) | TITLE: ROCKER SWITCH 1P1T | | |
| | RATING: AC 125V 11A ; AC 250V 5.5A | MODEL NO: U11WR-11N09-R1(00)-00 | | |
| | CONTACT RESISTANCE: MAX. 30mΩ | UNIT: mm | DWN | |
| | INSULATION RESISTANCE: 500MΩ at 500V DC | SCALE: 2 : 1 | CHK'D | |
| | WITHSTAND VOLTAGE: AC 1000V for 1 min | TOLERANCE: ±0.2 | APPD. | |
| | OPERATION FORCE: 600±300g | | | |
| | SWITCHING LIFE: 10,000 Cycles(6-10c/m loading) | | | |
| BY: | 广东科斯达电子科技有限公司 GUANG DONG KE SI DA ELECTRONIC TECHNOLOGY CO., LTD. | DRWG NO: | | |
| DATE: | | 980526-02 | | |