

NON-SHORTING
SCHEMATIC

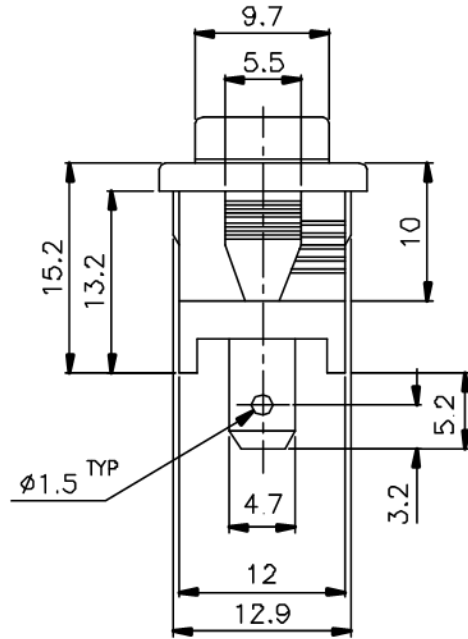

Panel Cut-out Dimensions

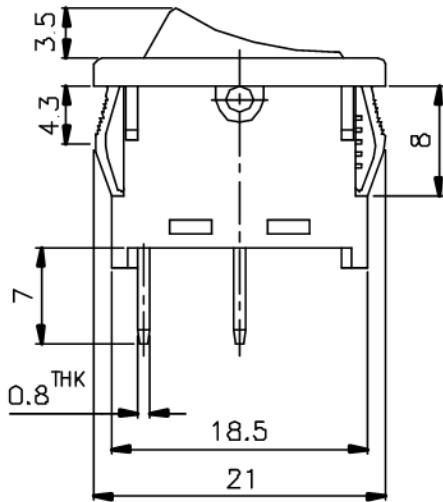
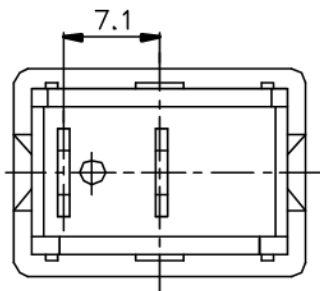
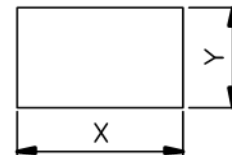

Panel Thickness (mm/inch)	DIM X ⁺⁰ _{-0.1} (mm/inch)	DIM Y ^{±0.1} (mm/inch)
0.5~1.2 (.02~.05)	19.4 (.764)	13.1 (.516)
1.2~2.0 (.05~.08)	19.7 (.775)	
2.0~3.0 (.08~.12)	20.0 (.787)	

Rating: U11 11A 125VAC
5.5A 250VAC

ISSUED	SPECIFICATION (INITIAL)	TITLE: ROCKER SWITCH 1P1T		
	RATING: AC 125V 11A ; 250V 5.5A	MODEL NO: U11WR-11N11-R1(00)		
	CONTACT RESISTANCE: MAX. 30mΩ	UNIT: mm	DWN	
	INSULATION RESISTANCE: 500MΩ at 500V DC	SCALE: 2 : 1	CHK'D	
	WITHSTAND VOLTAGE: AC 1000V for 1 min	TOLERANCE: ±0.2	APPD.	
	OPERATION FORCE: 600±200g			
	SWITCHING LIFE: 10000 Cycles(6-10c/m loading)			
BY:	广东科斯达电子科技有限公司 GUANG DONG KE SI DA ELECTRONIC TECHNOLOGY CO., LTD.	DRWG NO:		
DATE:		980529-00		