

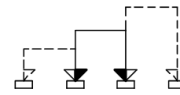

**KSD**

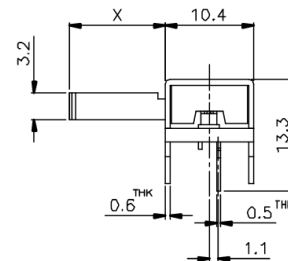

SCHEMATIC

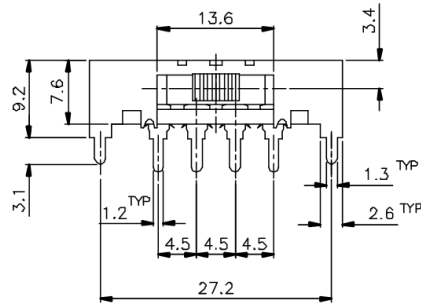
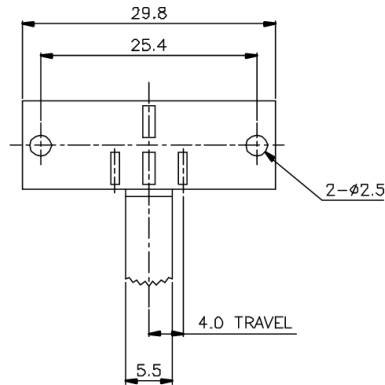

X=

ISSUED	SPECIFICATION (INITIAL)	TITLE: SLIDE SWITCH 1P3T	
	RATING: DC 125V 0.5A AC 125V 0.5A	MODEL NO:	SK-13H07-G
	CONTACT RESISTANCE: MAX. 30mΩ	UNIT: m m	DWN
	INSULATION RESISTANCE: 500MΩ at 500V DC	SCALE: 2 : 1	CHK'D
	WITHSTAND VOLTAGE: AC 1000V for 1 MIN	TOLERANCE: ±0.20	APPD.
	OPERATION FORCE: 200 ± 100 g		
	SWITCHING LIFE: 10,000 Cycles(6-10c/m loading)		
BY:	 <b>广东科斯达电子科技有限公司</b> GUANG DONG KE SI DA ELECTRONIC TECHNOLOGY CO., LTD.	DRWG NO:	900076-02
DATE:			