

SPECIFICATIONS

Circuit : SPST
 Current rating : 0.2A
 Voltage rating : 250VAC
 Dielectric withstanding voltage : 1000VAC for 1 minute
 Contact resistance : 50mΩ Max
 Insulation resistance : 100MΩ Min
 Travel : 2.0mm±0.5mm
 Operating Force : 500±150gf
 Mechanical Life : Over 200,000 cycles
 Electrical Life : Over 30,000 cycles
 Manual Welding Function : 350°C for 3 seconds
 Operating temperature : -20°C ~ +85°C
 Level of protection : IP65

MATERIAL:

Base: PA66, UL rated: 94V-2 Min;
 Cap: PA66 ;
 Terminal: Copper, Silver plated ;
 Nut: Brass, NI Plated .

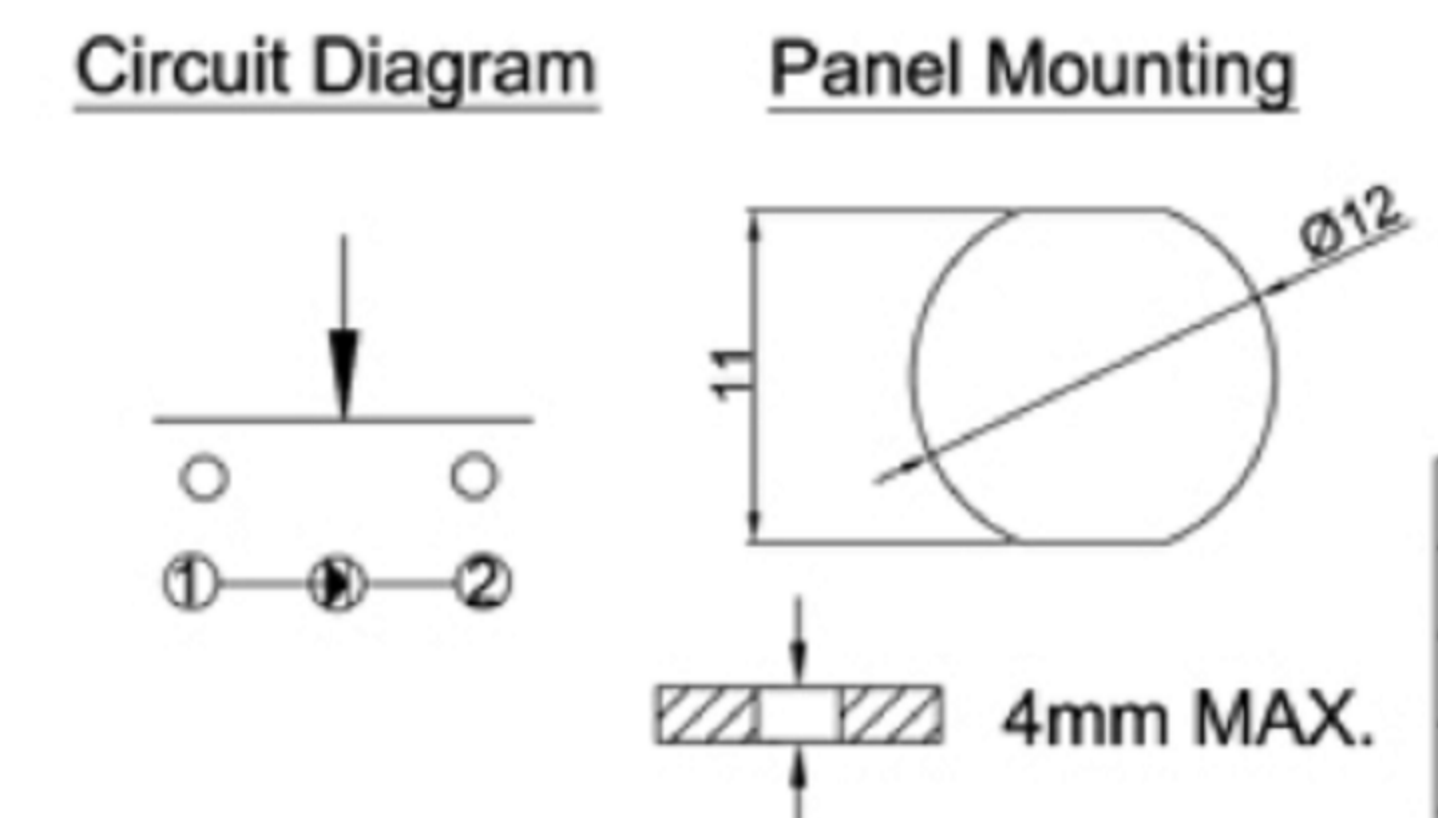

LED SPECIFICATIONS								
U (sv)	Blue 蓝色	5.0	6.0	7.0	25	100		
G (sv)	Green 绿色	5.0	6.0	7.0	25	100		
R (sv)	Red 红色	5.0	6.0	7.0	25	100		
B	Black 黑色	U	Blue 蓝色	2.9	3.0	3.4	20	100
W	White 白色	Y	Yellow 黄色	1.9	2.2	2.4	20	100
U	Blue 蓝色	G	Green 绿色	1.8	2.2	2.4	20	100
G	Green 绿色	R	Red 红色	1.9	2.2	2.4	20	100
R	Red 红色	W	White 白色	2.9	3.2	3.5	30	100
Cap Color (X) 上盖颜色 (X)	Clip emitted color (Y) 灯的发光颜色 (Y)	最小	一般	最大	最大操作电流 (mA)	最大脉冲电流 (mA)		
		顺向电压 (V)						

Note: This product is strictly prohibited wave soldering and reflow soldering, please use the manual welding processing, temperature of 350°±5° and time is 3±0.5 seconds;

 **广东科斯达电子科技有限公司**
 GUANG DONG KE SI DA ELECTRONIC TECHNOLOGY CO., LTD.

TOLERANCE UNLESS OTHERWISE STATED: Up to 5 ±0.2, Above 5 ~ 15 ±0.3, Above 15 ~ 30 ±0.4, Above 30 ~ 50 ±0.5, Angle ±0.3

3RD. ANGEL'S

UNITS: MM

DRAWN BY:	DATE	MAT'L	TITLE	SWITCH
Jack Lu	12/27/22			
CHECKED BY:	DATE	FINISH	MODLE	TACT SWITCH WITH LED
Jacky Chen	12/27/22			
APPROVED BY:	DATE	SCALE	DWG NO.	SIZE
Tony Kao	12/27/22	1 : 1		A4
		SHEET NO.	PART NO.	VER
		1 of 1		R