

Rating: 16A 125V AC (UL CUL)
16A 250V AC (ENEC CQC CB)

Contact Resistance: 50mΩ Max
Insulation Resistance: DC 500V 100MΩ Min.
Dielectric Strength: AC1500V 1 minute
Operating Force: 500±300gf
Mechanical Life: Over 30,000 cycles
Electrical Life: Over 10,000 cycles
Operating Temperature: -30°C ~ +85°C
Safety Approval:

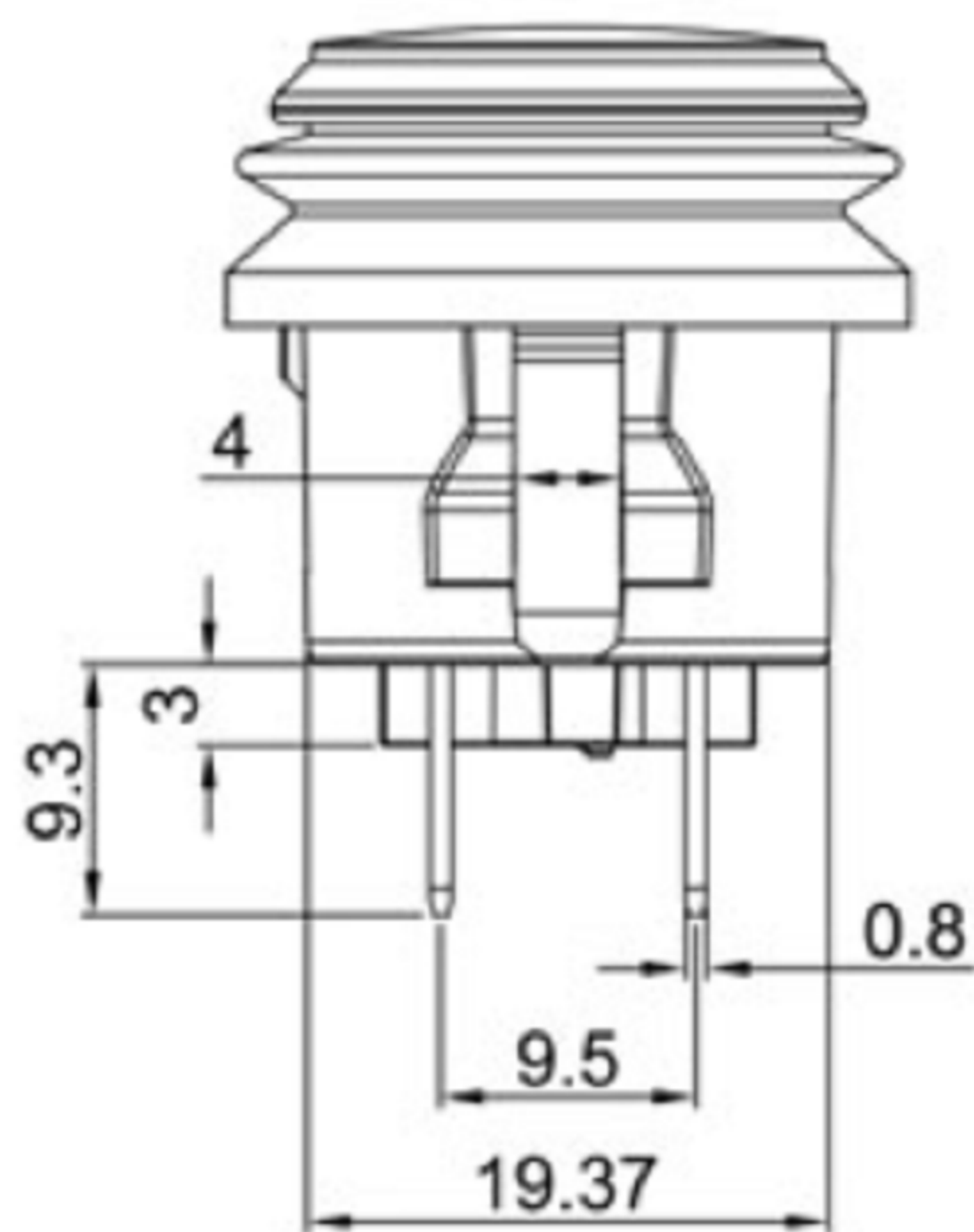

CUT-OUT

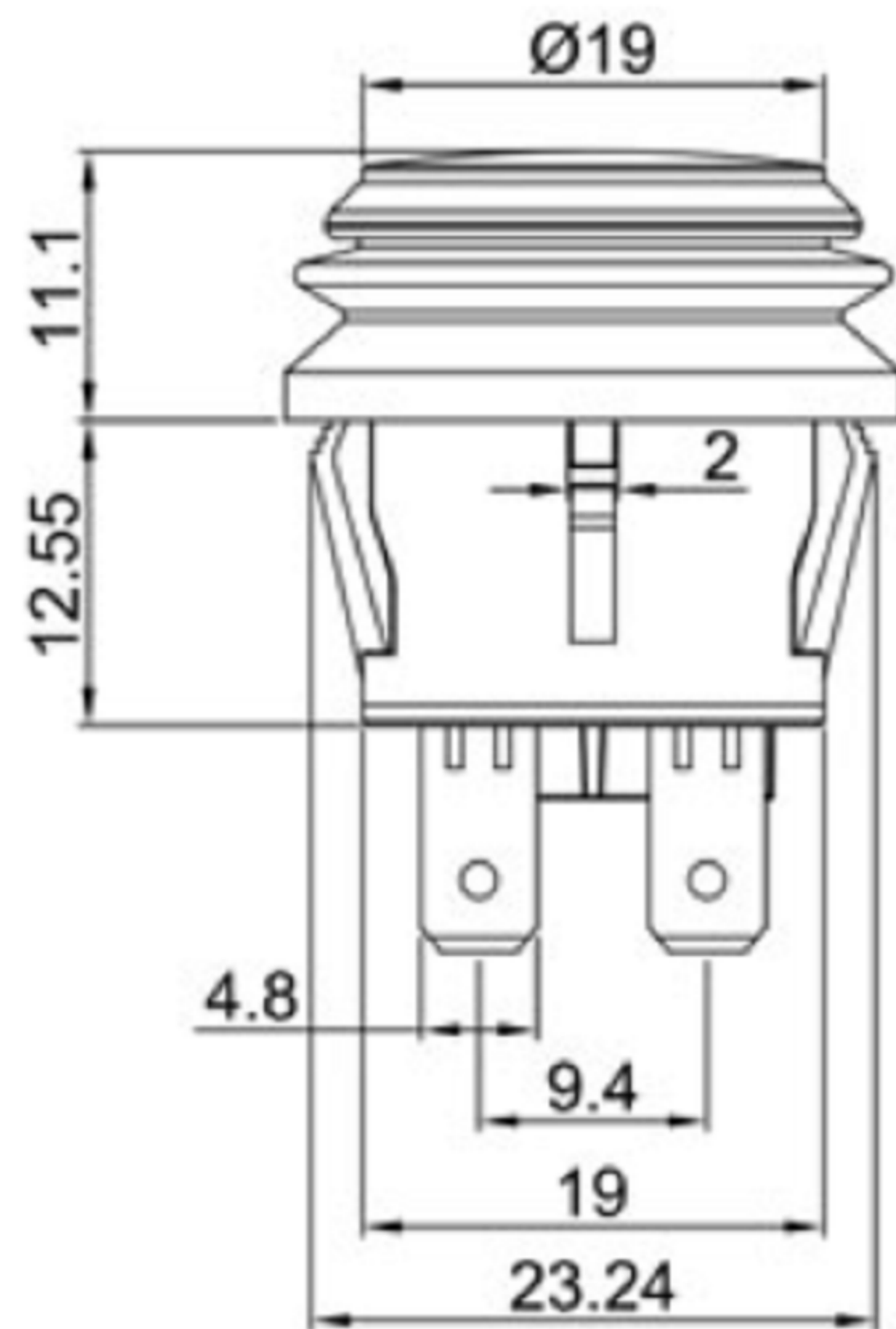
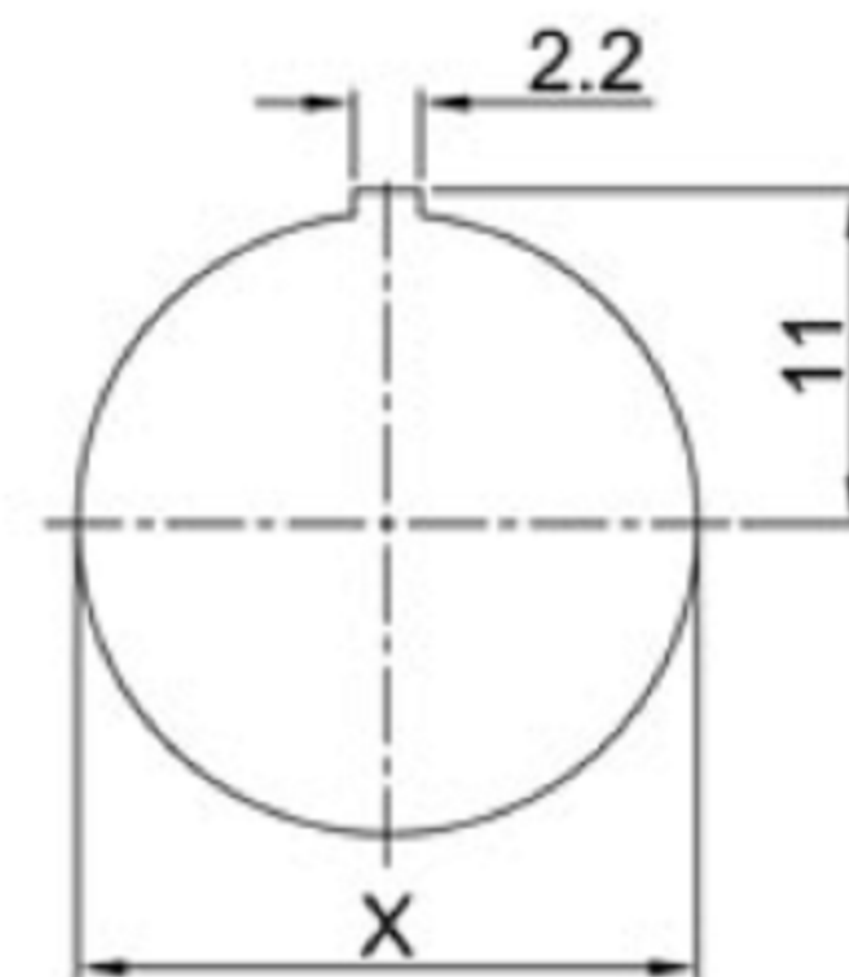

	X
0.75~1.25	20.2
1.25~2.00	20.4
2.00~3.00	20.6

SWITCHING CIRCUIT

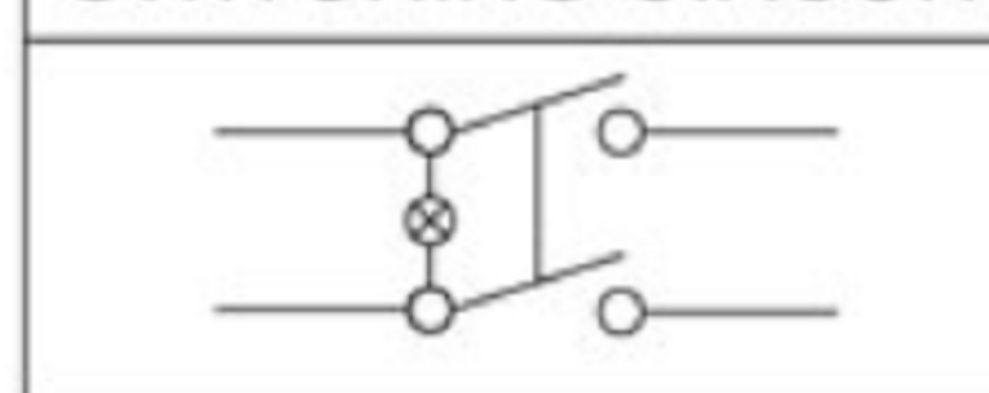

广东科斯达电子科技有限公司
GUANG DONG KE SI DA ELECTRONIC TECHNOLOGY CO., LTD.

TOLERANCE UNLESS OTHERWISE STATED: Up to 5 ±0.2, Above 5 ~ 15 ±0.3, Above 15 ~ 30 ±0.4, Above 30 ~ 50 ±0.5, Angle ±0.3
3RD. ANGEL'S UNITS MM

DRAWN BY:	DATE	MAT'L	TITLE	SWITCH
Jack Lu	12/27/22		MODLE	TACT SWITCH WITH LED
CHECKED BY:	DATE	FINISH	DWG NO.	SIZE
Jacky Chen	12/27/22			A4
APPROVED BY:	DATE	SCALE	PART NO.	VER
Tony Kao	12/27/22	1 : 1		R
		SHEET NO.		
		1 of 1		

ITEM NO.	DESCRIPTION	DRAWN	DATE