

**SPECIFICATIONS**

|                                 |                       |
|---------------------------------|-----------------------|
| Circuit                         | :SPST                 |
| Current rating                  | :0.1A / 2A            |
| Voltage rating                  | :24VDC/125VAC         |
| Dielectric withstanding voltage | :1000VAC for 1 minute |
| Contact resistance              | :50mΩ Max             |
| Insulation resistance           | :100MΩ Min            |
| Travel                          | :2.5mm±0.5mm          |
| Operating Force                 | :300±50gf             |
| Mechanical Life                 | :Over 100,000 cycles  |
| Electrical Life                 | :Over 10,000 cycles   |
| Manual Welding                  | :350°C for 3 seconds  |
| Function                        | :OFF-ON               |
| Operating temperature           | : -20°C ~ +85°C       |
| Level of Protection             | : IP65                |

**MATERIAL:**

Base: PA66,UL rated:94V-2 Min;  
 Cap: PA66 ;  
 Terminal: Copper,Golden plated ;  
 Nut: Brass, NI Plated .

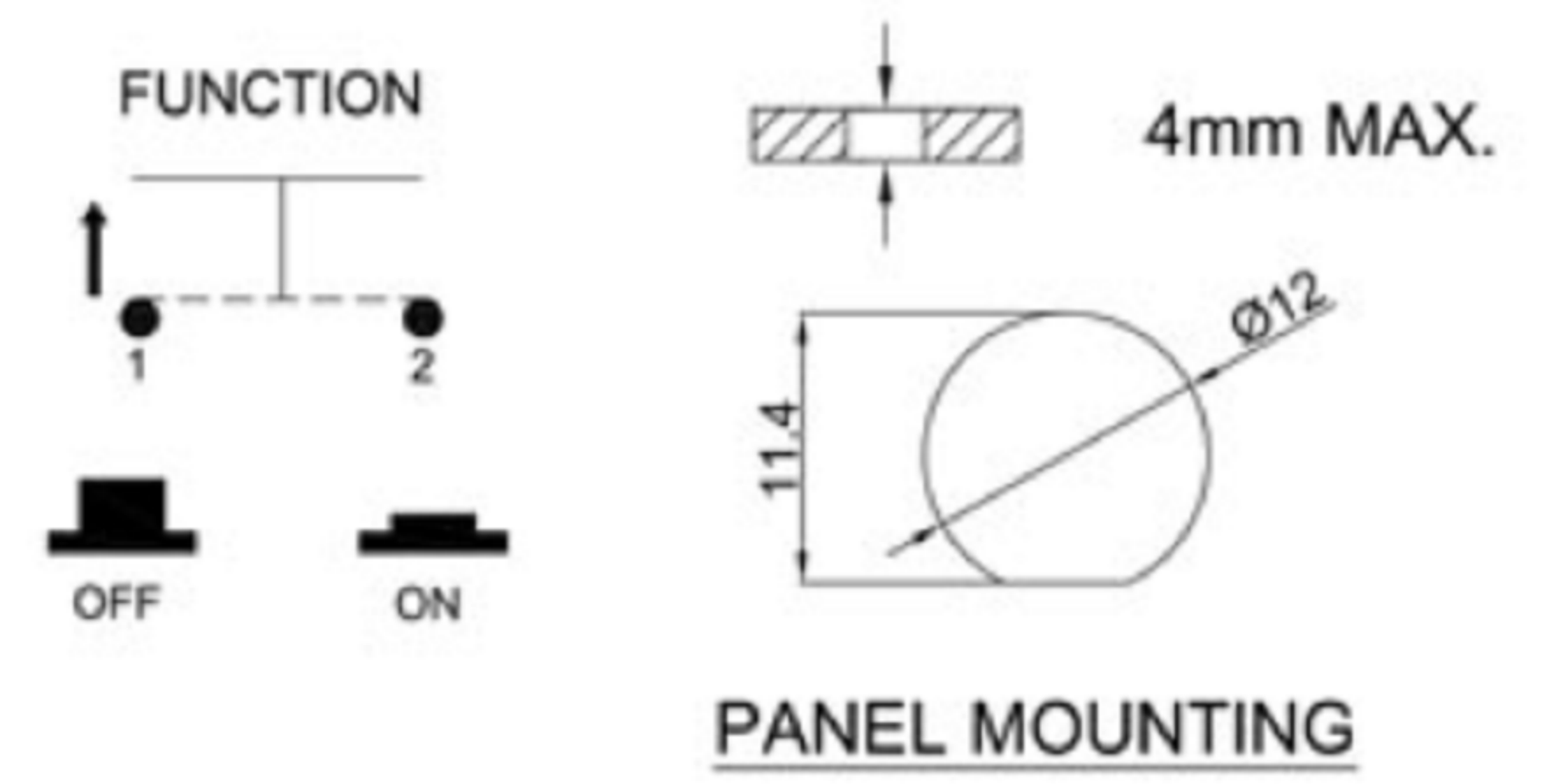

**Note:**  
 This product is strictly prohibited wave soldering and reflow soldering, please use the manual welding processing, temperature of  $350^{\circ} \pm 5^{\circ}$  and time is  $3 \pm 0.5$  seconds;

 **广东科斯达电子科技有限公司**  
 GUANG DONG KE SI DA ELECTRONIC TECHNOLOGY CO., LTD.

TOLERANCE UNLESS OTHERWISE STATED:  
 Up to 5 ±0.2  
 Above 5 ~ 15 ±0.3  
 Above 15 ~ 30 ±0.4  
 Above 30 ~ 50 ±0.5  
 Angle ±0.3

3RD. ANGEL'S

UNITS MM

|              |          |           |          |                      |
|--------------|----------|-----------|----------|----------------------|
| DRAWN BY:    | DATE     | MAT'L     | TITLE    | SWITCH               |
| Jack Lu      | 12/27/22 |           |          |                      |
| CHECKED BY:  | DATE     | FINISH    | MODLE    | TACT SWITCH WITH LED |
| Jacky Chen   | 12/27/22 |           |          |                      |
| APPROVED BY: | DATE     | SCALE     | DWG NO.  | SIZE                 |
| Tony Kao     | 12/27/22 | 1 : 1     |          | A4                   |
|              |          | SHEET NO. | PART NO. | VER                  |
|              |          | 1 of 1    |          | R                    |