

SPECIFICATIONS

Circuit	:SPST
Current rating	:0.2A
Voltage rating	:250VAC
Dielectric withstanding voltage	:1000VAC for 1 minute
Contact resistance	:50mΩ Max
Insulation resistance	:100MΩ Min
Travel	:2.0mm±0.5mm
Operating Force	:500±150gf
Mechanical Life	:Over 500,000 cycles
Electrical Life	:Over 50,000 cycles
Manual Welding	:350°C for 3 seconds
Function	:Momentary
Operating temperature	:-40°C ~ +85°C
Level of protection	: IP67

MATERIAL:
 Housing: PA66,UL rated:94 V-2 Min;
 Base: FR50,UL rated:94 V-0 Min;
 Cap: PA66 ,UL rated:94 V-2 Min;
 Terminal: Copper,Golden plated ;

备注:
 按键帽颜色黑色
 基座颜色黑色
 底盖(后盖) 颜色白色

B	Black 黑色
W	White 白色
U	Blue 蓝色
G	Green 绿色
R	Red 红色
上盖颜色 X	
Cap color X	

Circuit Diagram

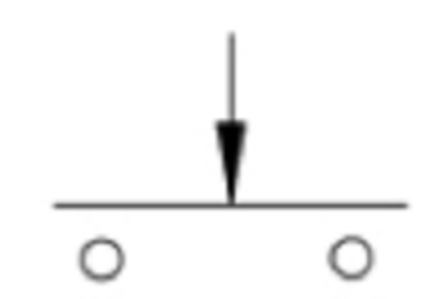

PANEL MOUNTING

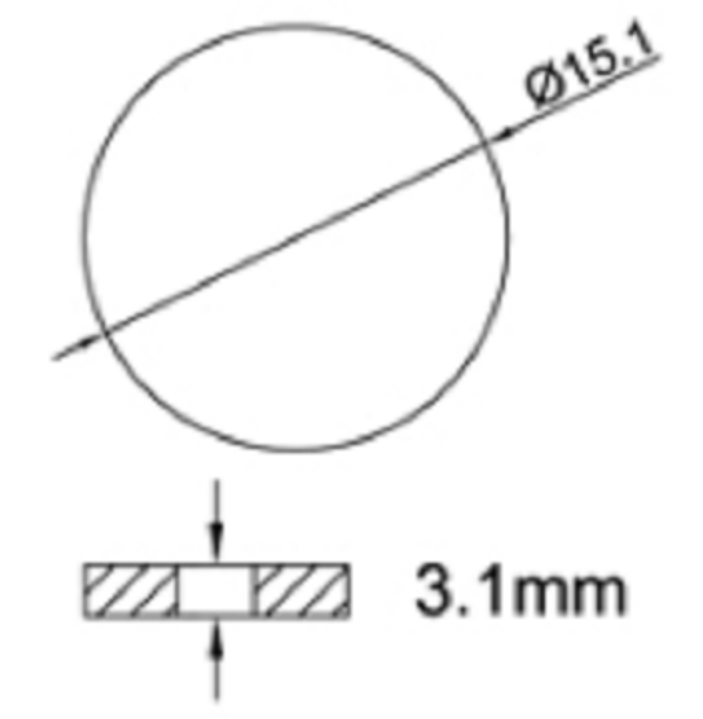

广东科斯达电子科技有限公司
 GUANG DONG KE SI DA ELECTRONIC TECHNOLOGY CO., LTD.

TOLERANCE UNLESS OTHERWISE STATED:	Up to 5 ±0.2	3RD. ANGEL'S	UNITS	MM
	Above 5 ~ 15 ±0.3			
	Above 15 ~ 30 ±0.4			
	Above 30 ~ 50 ±0.5			
	Angle ±0.3			

DRAWN BY:	DATE	MAT'L	TITLE	SWITCH
Jack Lu	12/27/22			
CHECKED BY:	DATE	FINISH	MODLE	TACT SWITCH WITH LED
Jacky Chen	12/27/22			
APPROVED BY:	DATE	SCALE	DWG NO.	SIZE
Tony Kao	12/27/22	1 : 1		A4
		SHEET NO.	PART NO.	VER
		1 of 1		R

ITEM NO.	DESCRIPTION	DRAWN	DATE