

SPECIFICATIONS
 Circuit :SPST
 Current rating :0.2A
 Voltage rating :250VAC
 Dielectric withstanding voltage :1000VAC for 1 minute
 Contact resistance :50mΩ Max
 Insulation resistance :100MΩ Min
 Travel :2.0mm±0.5mm
 Operating Force :500±150gf
 Mechanical Life :Over 200,000 cycles
 Electrical Life :Over 30,000 cycles
 Manual Welding :350°C for 3 seconds
 Function :Momentary
 Operating temperature : -20°C ~ +85°C
 Level of protection : IP67

MATERIAL:
 Base: PA66,UL rated:94V-2 Min;
 Cap: PA66 ;
 Terminal: Copper,Silver plated ;
 Nut: Brass, NI Plated .

Note:
 This product is strictly prohibited wave soldering and reflow soldering, please use the manual welding processing, temperature of 350°±5° and time is 3±0.5 seconds;

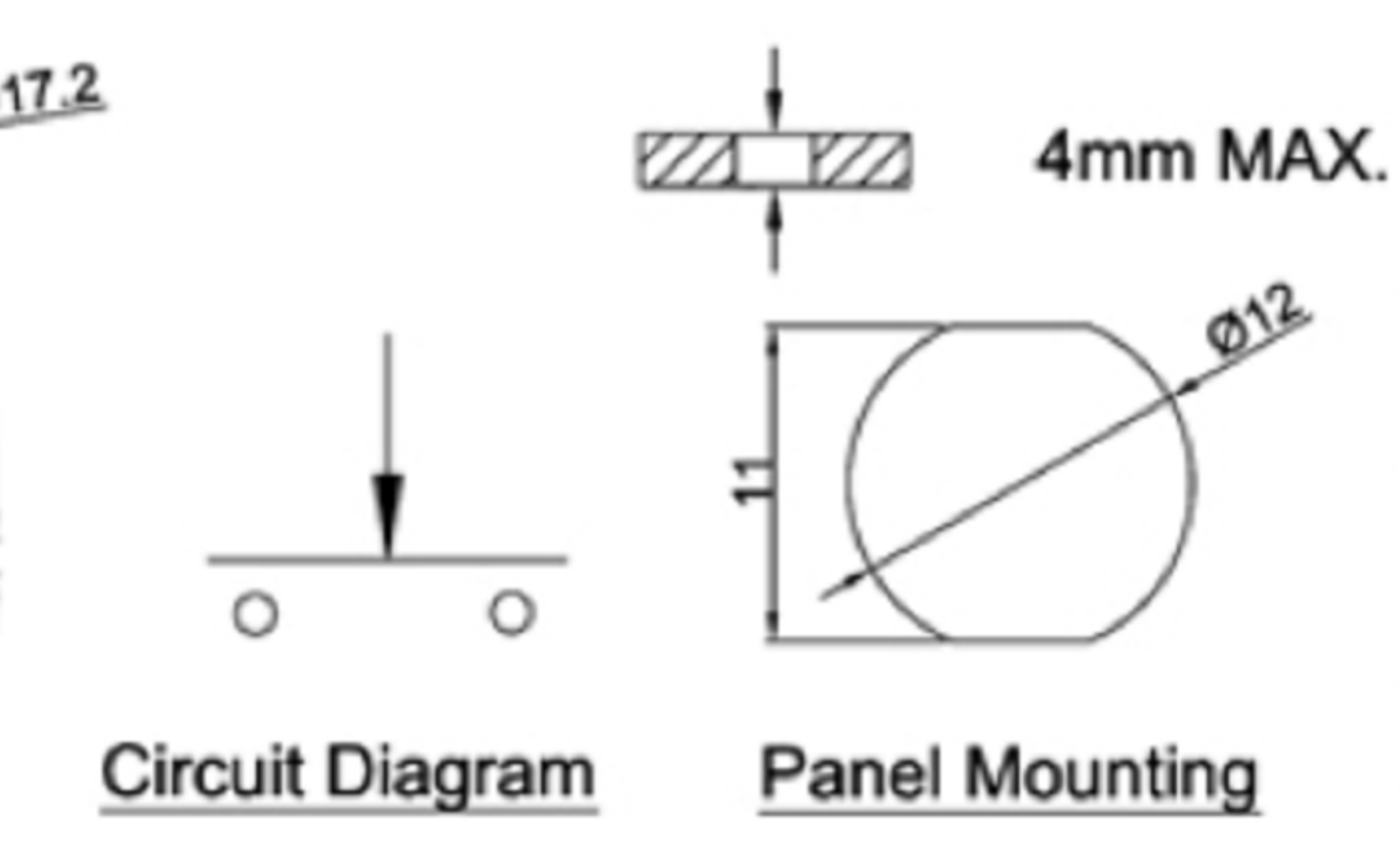

B	Black 黑色
W	White 白色
U	Blue 蓝色
G	Green 绿色
R	Red 红色
上盖颜色 X	
Cap color X	

广东科斯达电子科技有限公司
 GUANG DONG KE SI DA ELECTRONIC TECHNOLOGY CO., LTD.

TOLERANCE UNLESS OTHERWISE STATED :
 Up to 5 ±0.2
 Above 5 ~ 15 ±0.3
 Above 15 ~ 30 ±0.4
 Above 30 ~ 50 ±0.5
 Angle ±0.3

3RD. ANGEL'S

UNITS MM

DRAWN BY:	DATE	MAT'L	TITLE	SWITCH
Jack Lu	12/27/22			
CHECKED BY:	DATE	FINISH	MODLE	TACT SWITCH WITH LED
Jacky Chen	12/27/22			
APPROVED BY:	DATE	SCALE	DWG NO.	
Tony Kao	12/27/22	1 : 1		
		SHEET NO.	PART NO.	
		1 of 1		
				SIZE A4
				VER R