

SPECIFICATIONS

Circuit	:SPST
Current rating	:100mA
Voltage rating	:12VDC
Dielectric withstanding voltage	:250VAC for 1 minute (between contacts) (between contacts & case)
Contact resistance	:200mΩ Max. (Initial)
Insulation resistance	:100MΩ Min.
Operating force	:250±100gf
Full travel	:4.5mm±0.2mm
Mechanical life	:Over 2,000,000 cycles
Electrical life	:Over 1,000,000 cycles
Manual welding	:350°C for 3 seconds
Operating temperature	:-20°C ~ +70°C
Function	:OFF-(ON)

MATERIAL:

Base:PA+GF,UL rated:94 V-2 Min.
Cap:PC
Terminal:Brass, Silver plated;

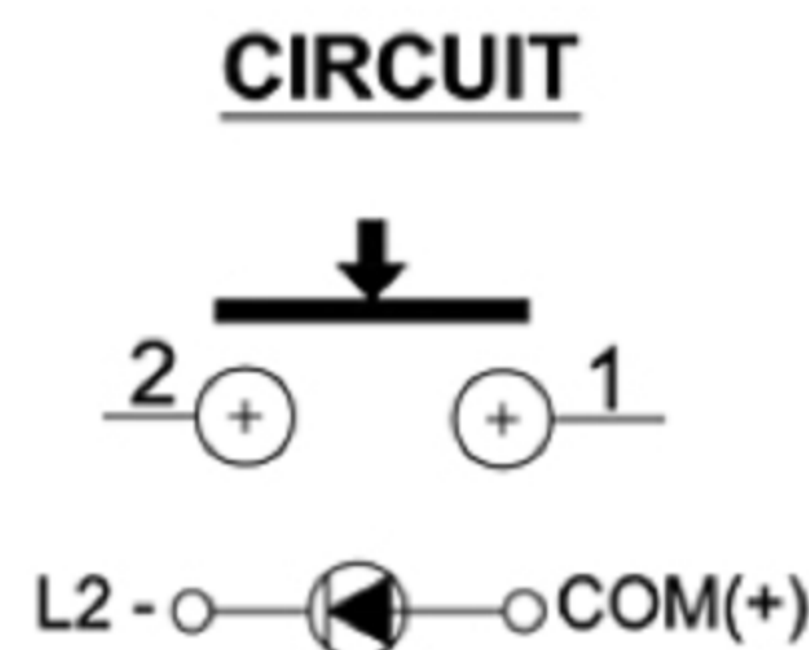
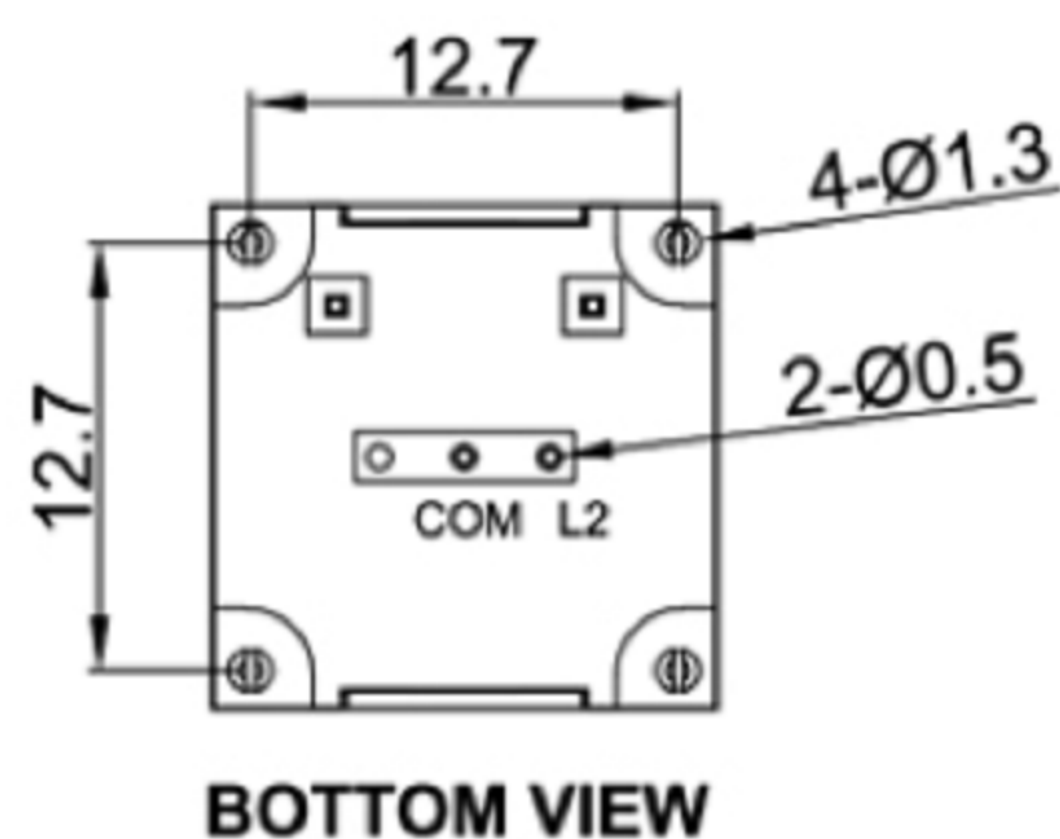

P.C.B. LAYOUT

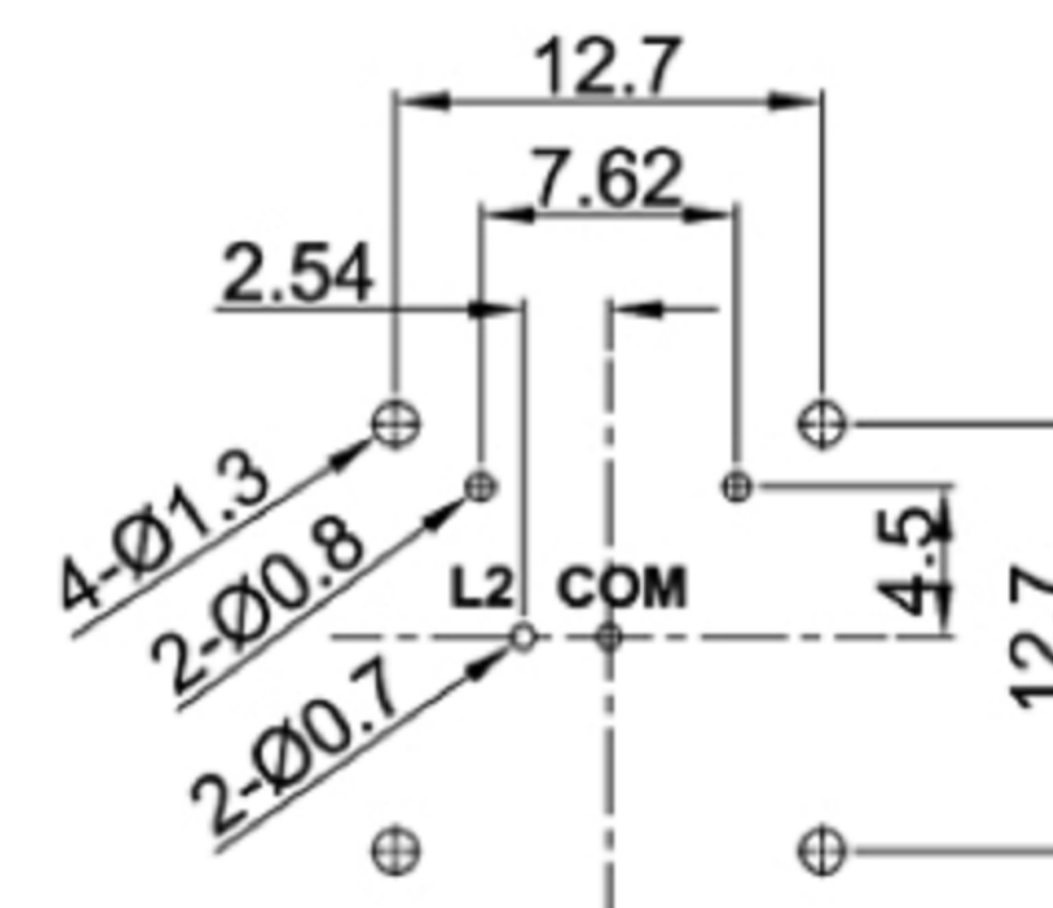

 **广东科斯达电子科技有限公司**
GUANG DONG KE SI DA ELECTRONIC TECHNOLOGY CO., LTD.

TOLERANCE UNLESS OTHERWISE STATED: Up to 5 ±0.2, Above 5 ~ 15 ±0.3, Above 15 ~ 30 ±0.4, Above 30 ~ 50 ±0.5, Angle ±0.3

3RD. ANGEL'S

UNITS MM

DRAWN BY:	DATE	MAT'L	TITLE	SWITCH
Jack Lu	12/27/22			
CHECKED BY:	DATE	FINISH	MODLE	TACT SWITCH WITH LED
Jacky Chen	12/27/22			
APPROVED BY:	DATE	SCALE	DWG NO.	SIZE
Tony Kao	12/27/22	1 : 1		A4
		SHEET NO.	PART NO.	VER
		1 of 1		R