

SPECIFICATIONS

Circuit	:SPST
Switch voltage rating	:1.5A 250VAC, 3A125VAC
Dielectric withstanding voltage	:1500VAC for 1 minute
Contact resistance	:20mΩ Max. (Initial)
Insulation resistance	:100MΩ Min.
Electrical Life	:25,000 cycles Min
Function	: OFF-ON
Operating temperature	:-25° C ~ +85° C

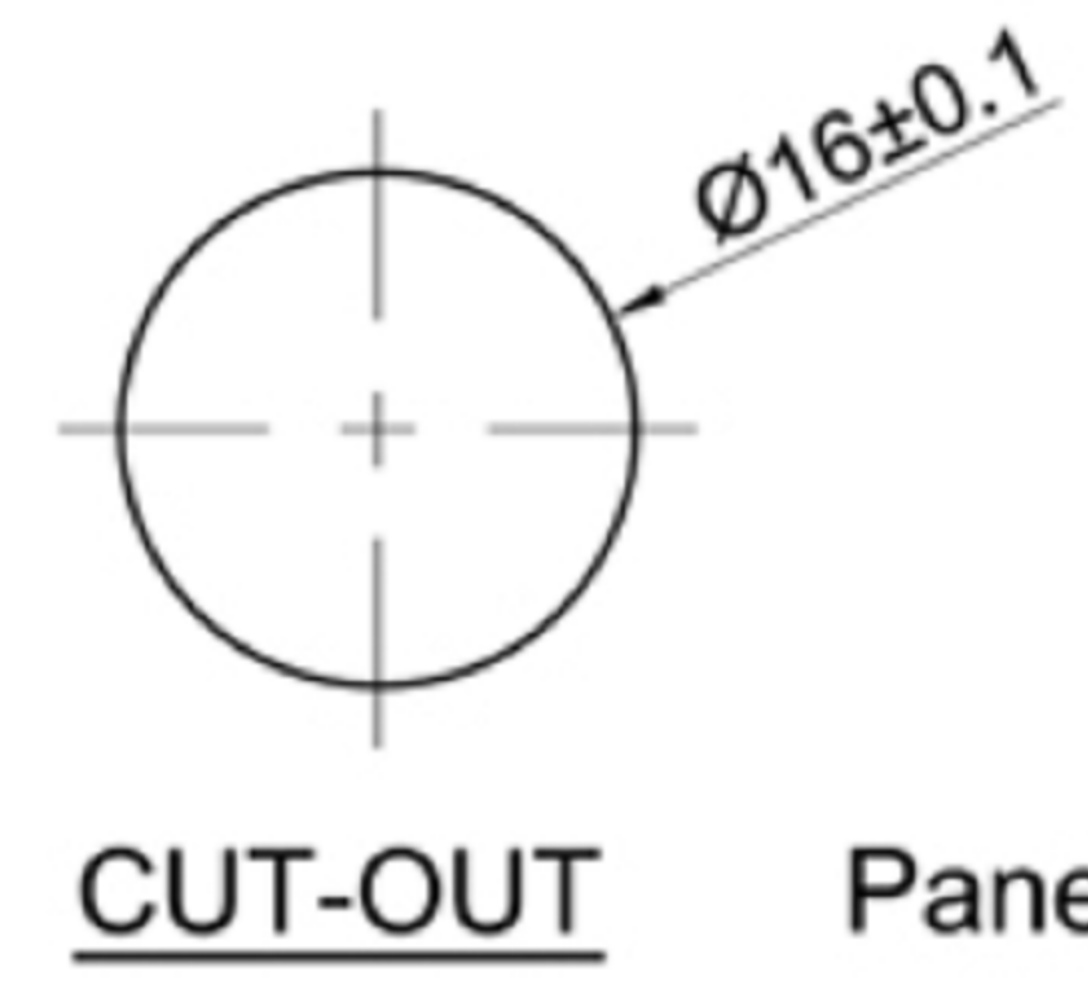
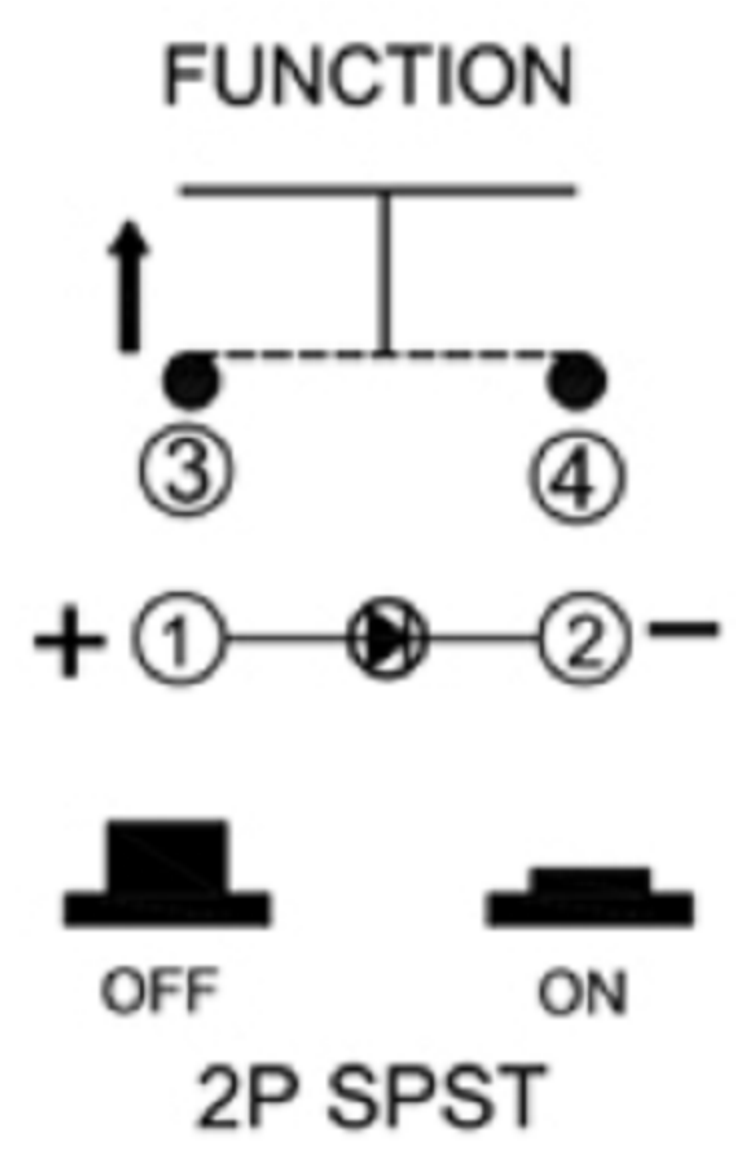
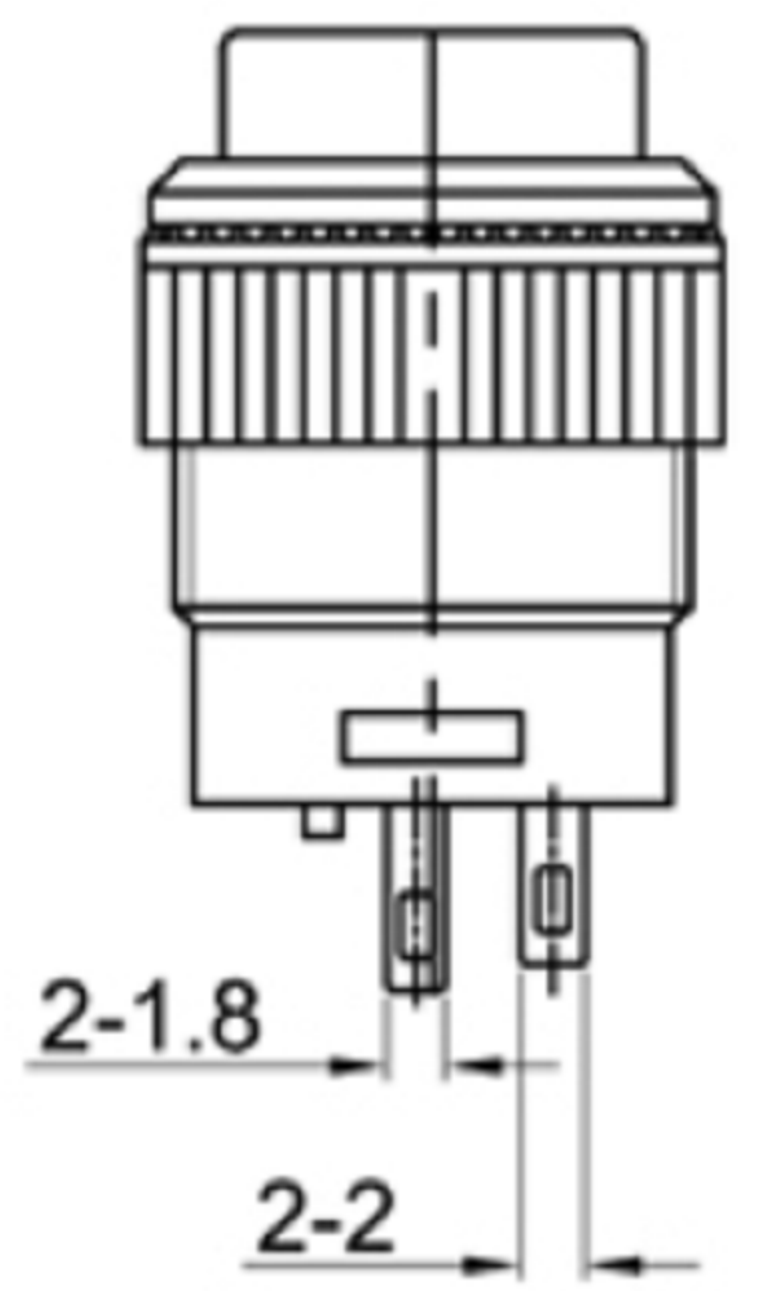

Panel Thickness: 3mm MAX.

 **广东科斯达电子科技有限公司**
GUANG DONG KE SI DA ELECTRONIC TECHNOLOGY CO., LTD.

TOLERANCE UNLESS OTHERWISE STATED:
 Up to 5 ±0.2
 Above 5 ~ 15 ±0.3
 Above 15 ~ 30 ±0.4
 Above 30 ~ 50 ±0.5
 Angle ±0.3

3RD. ANGEL'S

UNITS MM

DRAWN BY:	DATE	MAT'L	TITLE	SWITCH
Jack Lu	12/27/22			
CHECKED BY:	DATE	FINISH	MODLE	TACT SWITCH WITH LED
Jacky Chen	12/27/22			
APPROVED BY:	DATE	SCALE	DWG NO.	SIZE
Tony Kao	12/27/22	1:1		A4
		SHEET NO.	PART NO.	VER
		1 of 1		R