

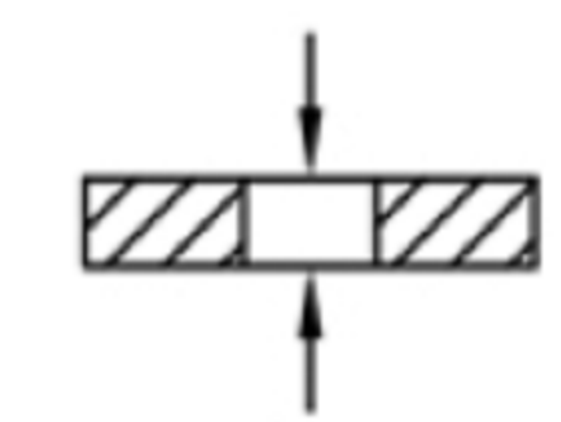

SPECIFICATIONS

Circuit	:SPST
Switch voltage rating	:1.5A 250VAC,3A 125VAC
Dielectric withstanding voltage	:1500VAC for 1 minute
Contact resistance	:20mΩ Max. (Initial)
Insulation resistance	:100MΩ Min.
Electrical Life	:50,000 cycles Min
Function	: OFF-(ON)
Operating temperature	:-25° C ~ +85° C

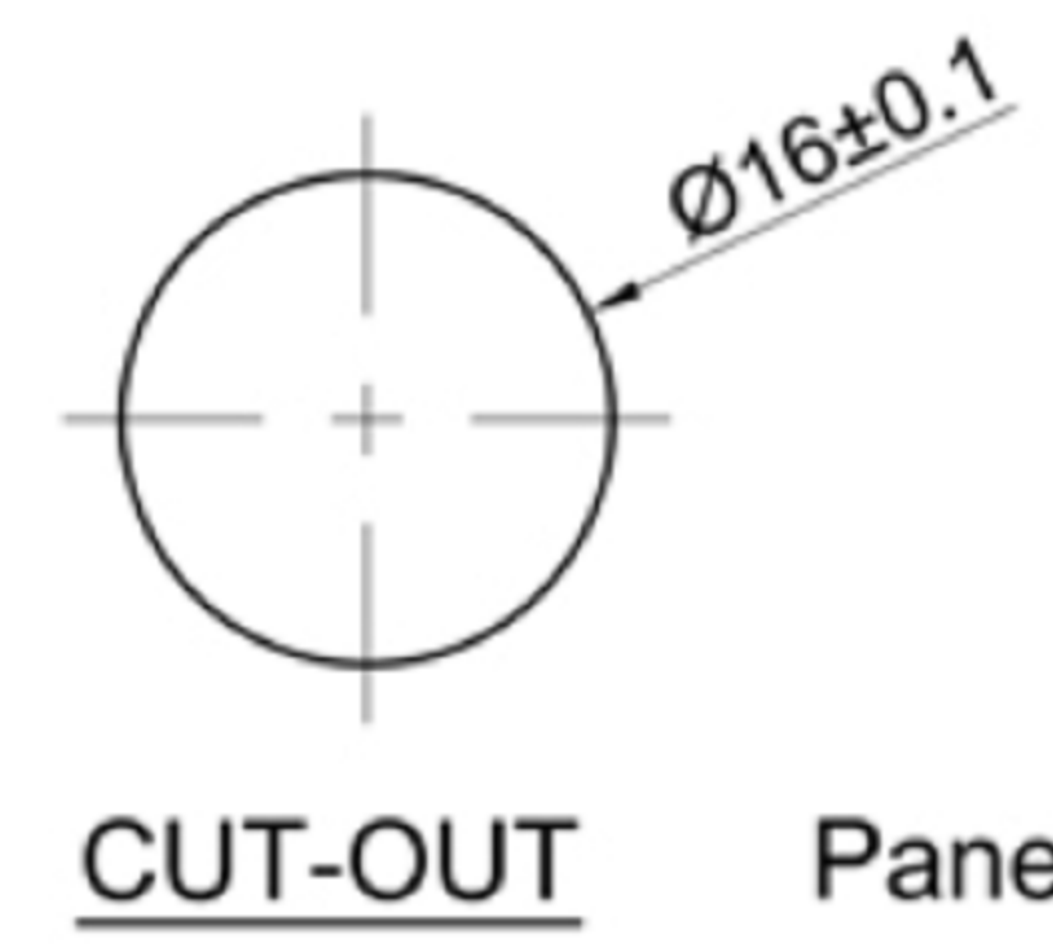
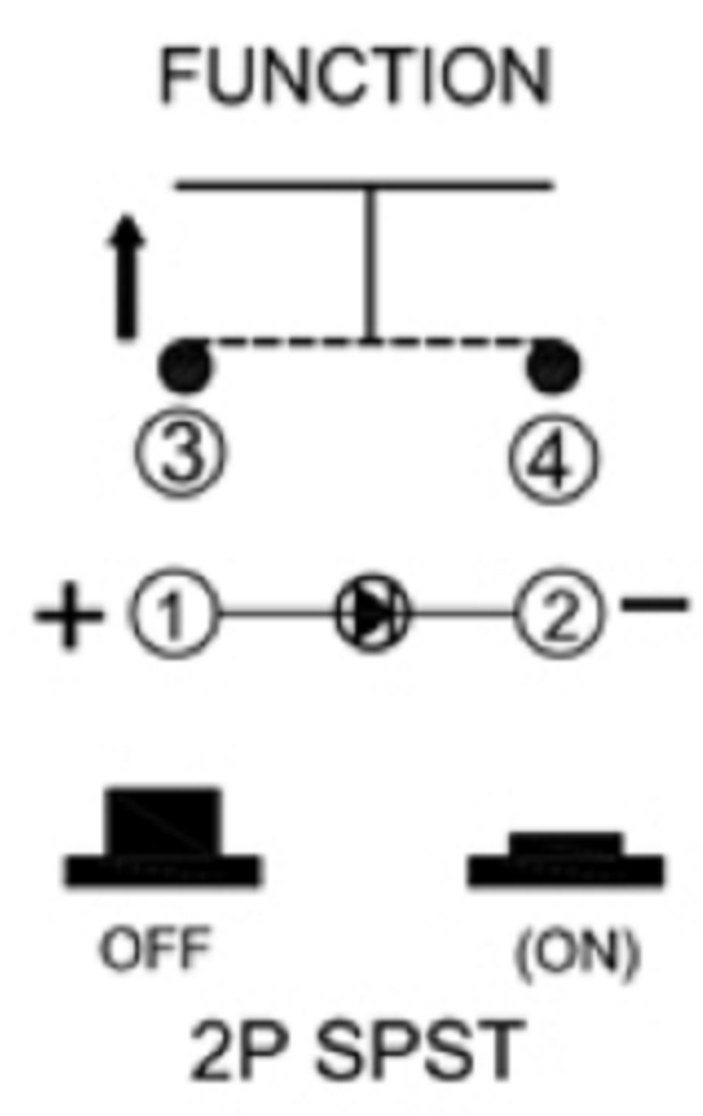
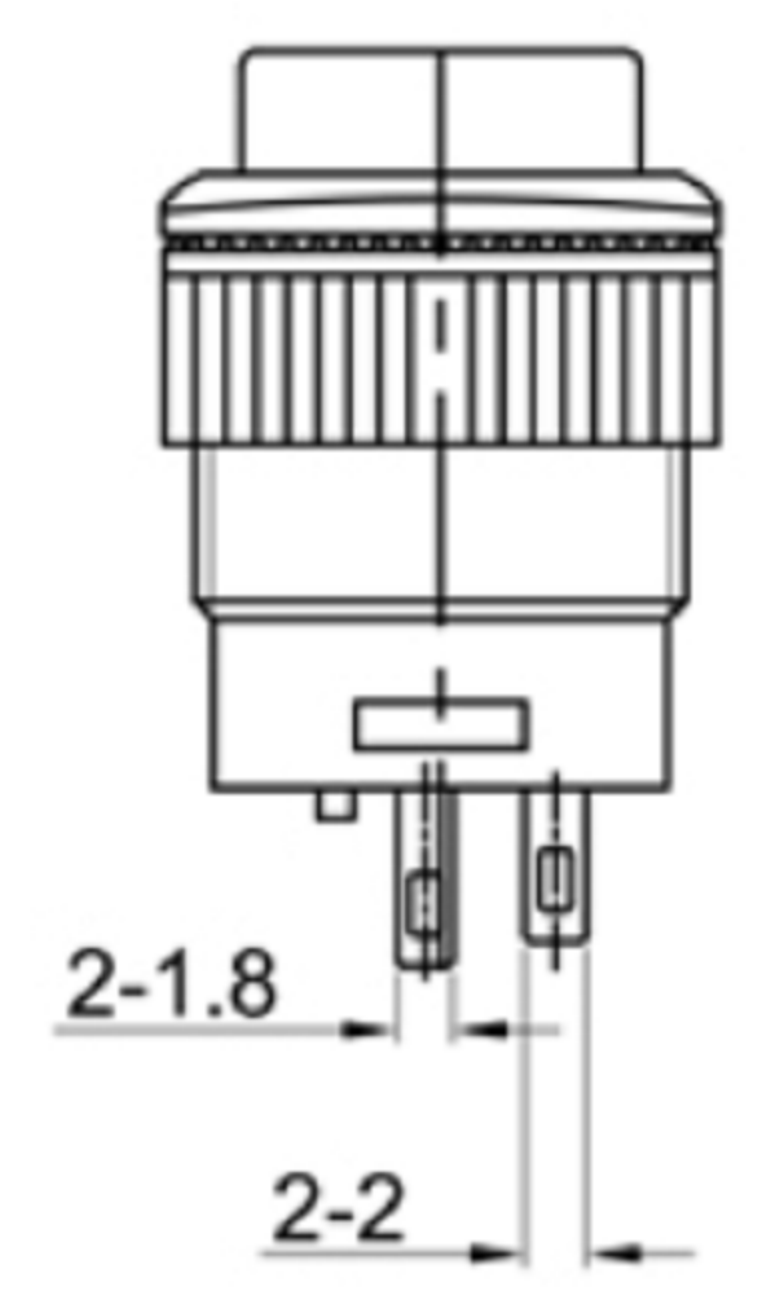
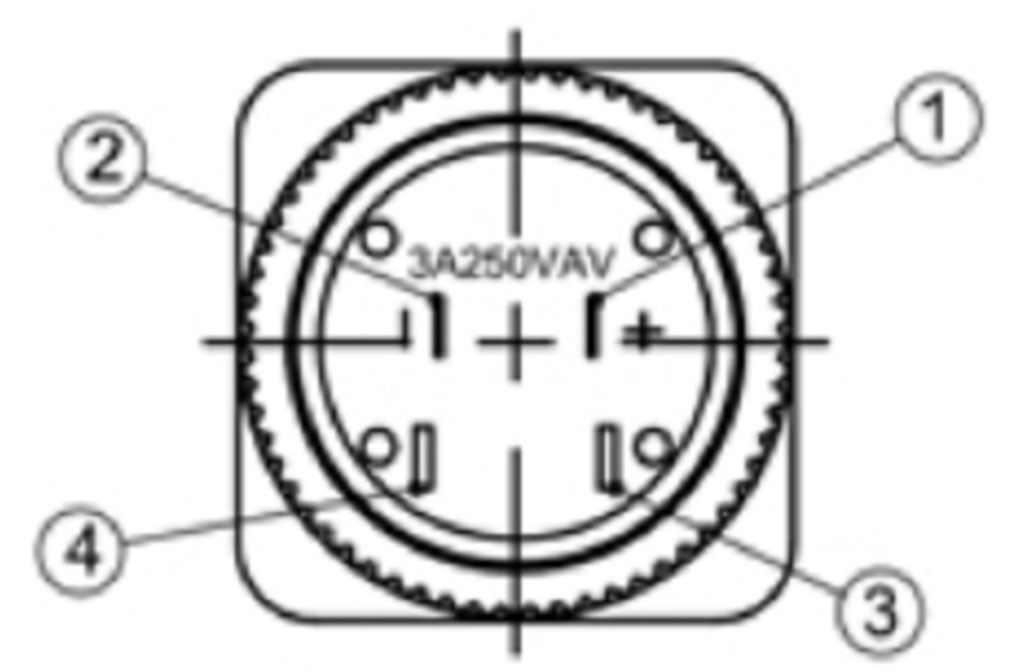

Panel Thickness: 3mm MAX.

广东科斯达电子科技有限公司
 GUANG DONG KE SI DA ELECTRONIC TECHNOLOGY CO., LTD.

TOLERANCE UNLESS OTHERWISE STATED:	Up to 5 ±0.2	Above 5 ~ 15 ±0.3	Above 15 ~ 30 ±0.4	Above 30 ~ 50 ±0.5	Angle ±0.3	3RD. ANGEL'S	UNITS	MM
------------------------------------	--------------	-------------------	--------------------	--------------------	------------	--------------	-------	----

DRAWN BY:	DATE	MAT'L	TITLE	SWITCH
Jack Lu	12/27/22			
CHECKED BY:	DATE	FINISH	MODLE	TACT SWITCH WITH LED
Jacky Chen	12/27/22			
APPROVED BY:	DATE	SCALE	DWG NO.	SIZE
Tony Kao	12/27/22	1 : 1		A4
		SHEET NO.	PART NO.	VER
		1 of 1		R

ITEM NO.	DESCRIPTION	DRAWN	DATE