

**SPECIFICATIONS**

- Circuit :SPST
- Current rating :100mA
- Voltage rating :12VDC
- Dielectric withstanding voltage :250VAC for 1 minute  
(between contacts)  
(between contacts & case)
- Contact resistance :200mΩ Max. (Initial)
- Insulation resistance :100MΩ Min.
- Operating force :250±100gf
- Full travel :4.5mm±0.2mm
- Mechanical life :Over 2,000,000 cycles
- Electrical life :Over 1,000,000 cycles
- Manual welding :350°C for 3 seconds
- Operating temperature :-20°C ~ +70°C
- Function :OFF-(ON)

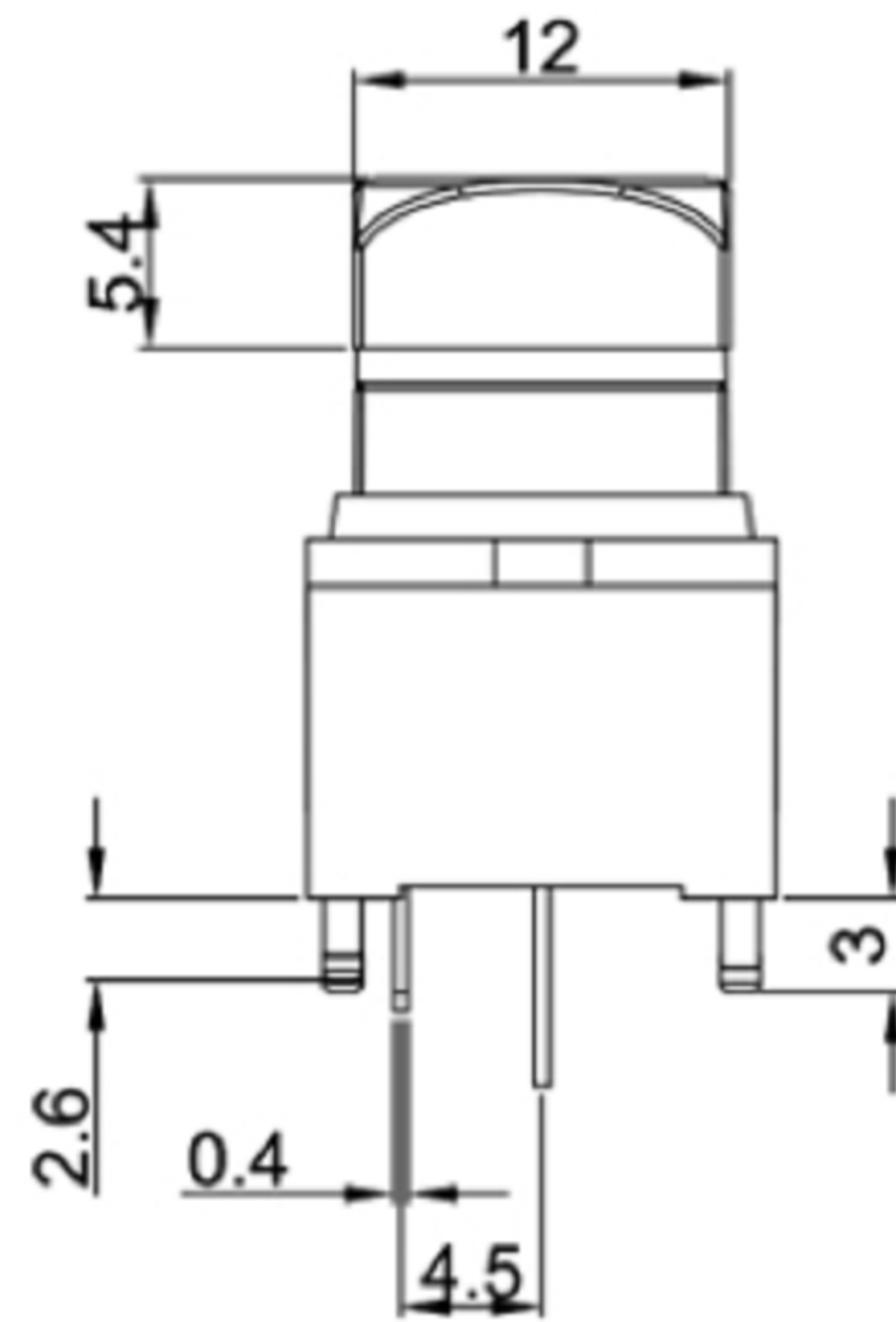
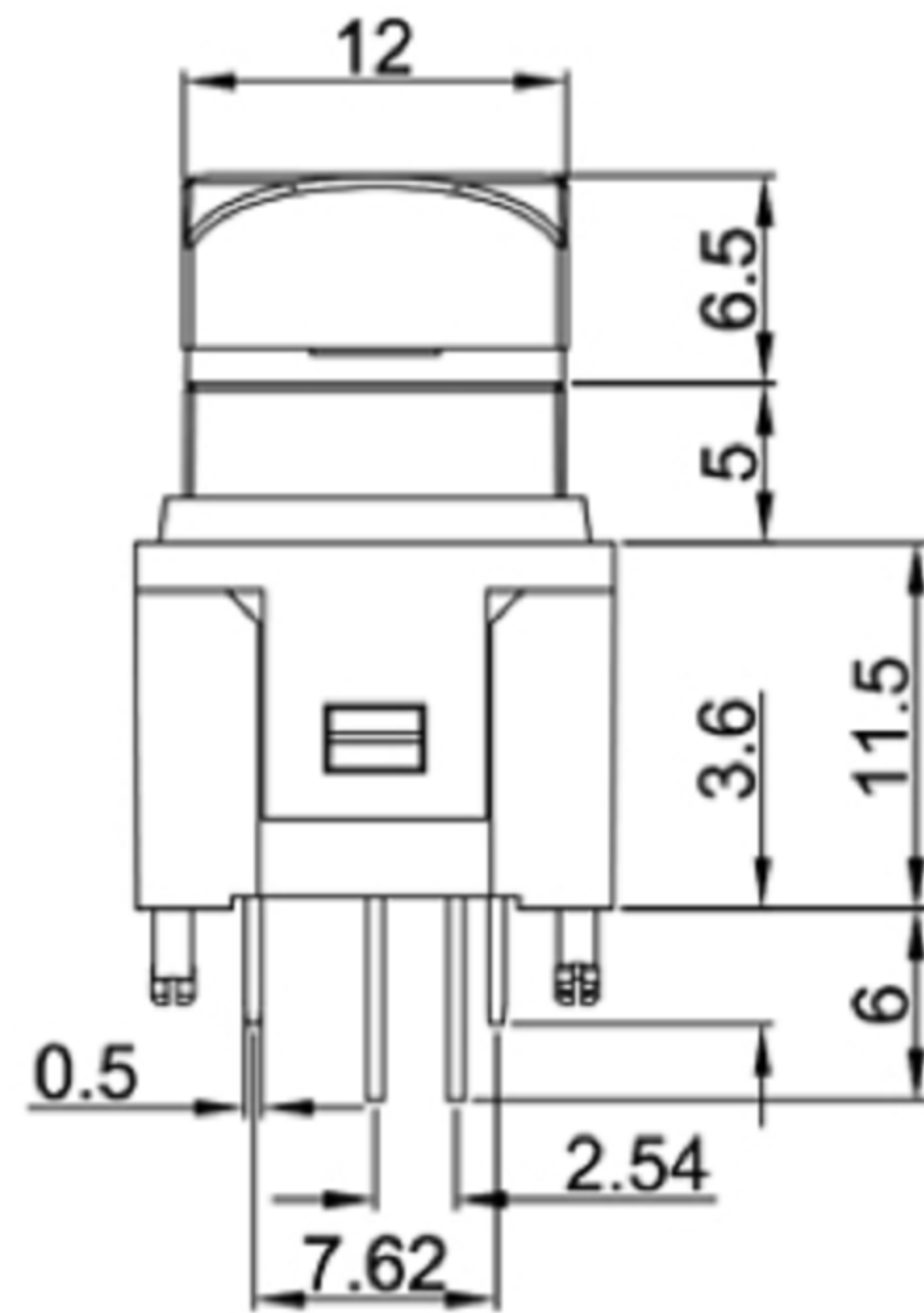

**MATERIAL:**

- Base:PA+GF,UL rated:94 V-2 Min.
- Cap:PC
- Terminal:Brass, Silver plated;

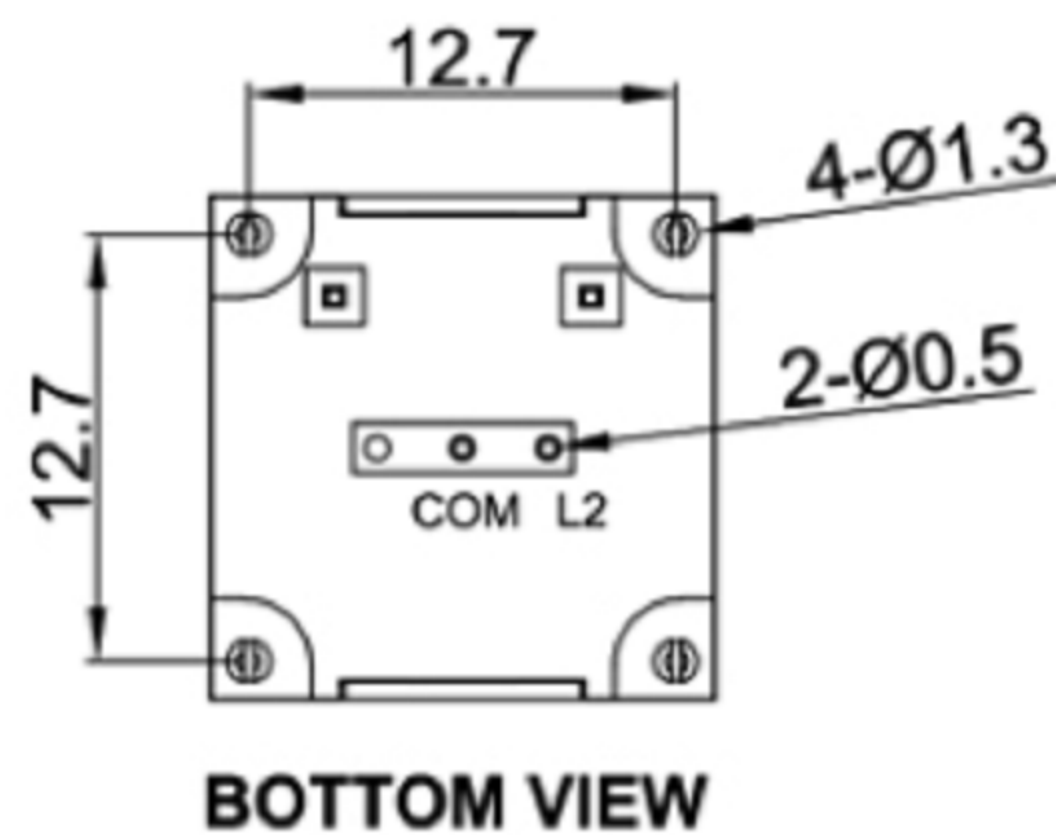

**CIRCUIT**

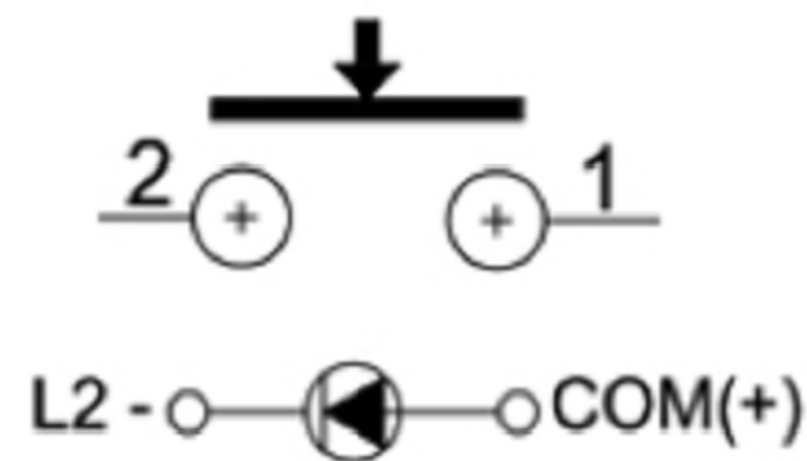

**P.C.B. LAYOUT**

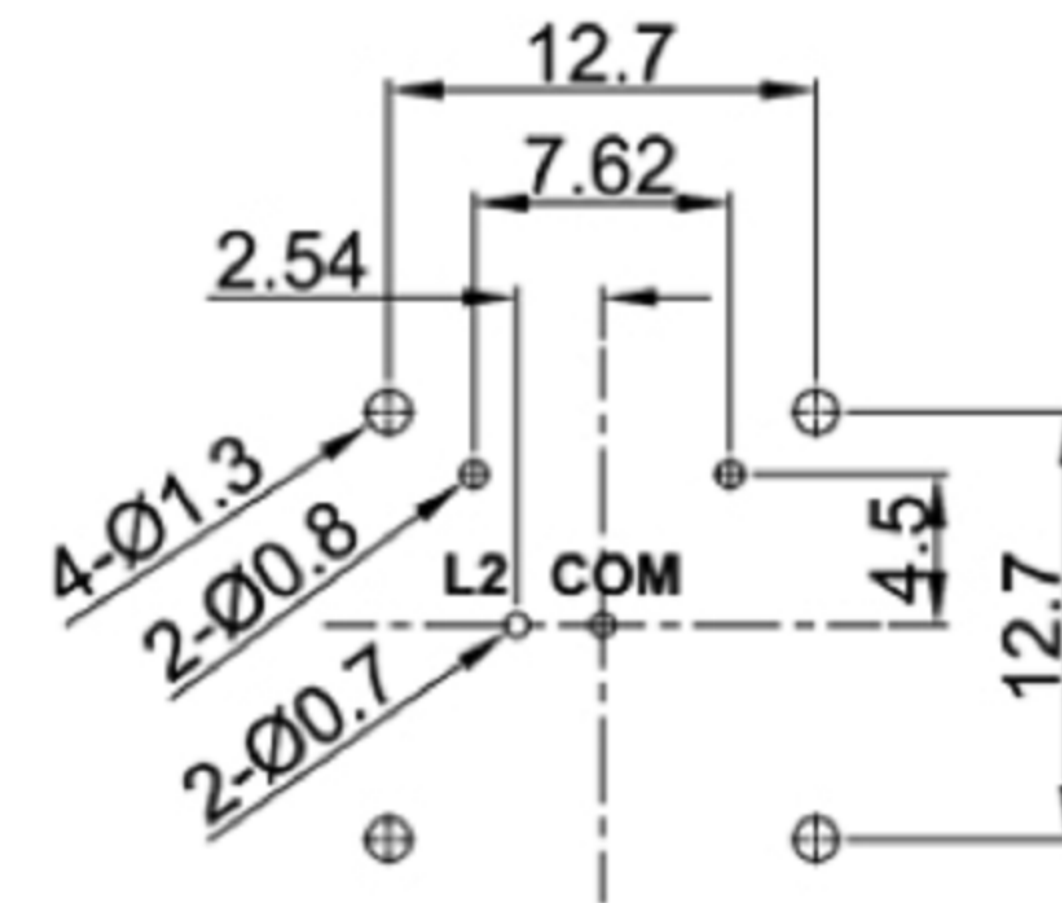

 **广东科斯达电子科技有限公司**  
**GUANG DONG KE SI DA ELECTRONIC TECHNOLOGY CO., LTD.**

TOLERANCE UNLESS OTHERWISE STATED: Up to 5 ±0.2, Above 5 ~ 15 ±0.3, Above 15 ~ 30 ±0.4, Above 30 ~ 50 ±0.5, Angle ±0.3

3RD. ANGEL'S

UNITS MM

DRAWN BY:	DATE	MAT'L	TITLE	SWITCH
Jack Lu	12/27/22			
CHECKED BY:	DATE	FINISH	MODLE	TACT SWITCH WITH LED
Jacky Chen	12/27/22			
APPROVED BY:	DATE	SCALE	DWG NO.	SIZE
Tony Kao	12/27/22	1 : 1		A4
		SHEET NO.	PART NO.	VER
		1 of 1		R