

SPECIFICATIONS

- Circuit :SPST
- Current rating :100mA
- Voltage rating :12VDC
- Dielectric withstanding voltage :250VAC for 1 minute
(between contacts)
(between contacts & case)
- Contact resistance :200mΩ Max. (Initial)
- Insulation resistance :100MΩ Min.
- Operating force :250±100gf
- Full travel :4.5mm±0.2mm
- Mechanical life :Over 2,000,000 cycles
- Electrical life :Over 1,000,000 cycles
- Manual welding :350°C for 3 seconds
- Operating temperature :-20°C ~ +70°C
- Function :OFF-(ON)

MATERIAL:

- Base:PA+GF,UL rated:94 V-2 Min.
- Cap:PC
- Terminal:Brass, Silver plated;

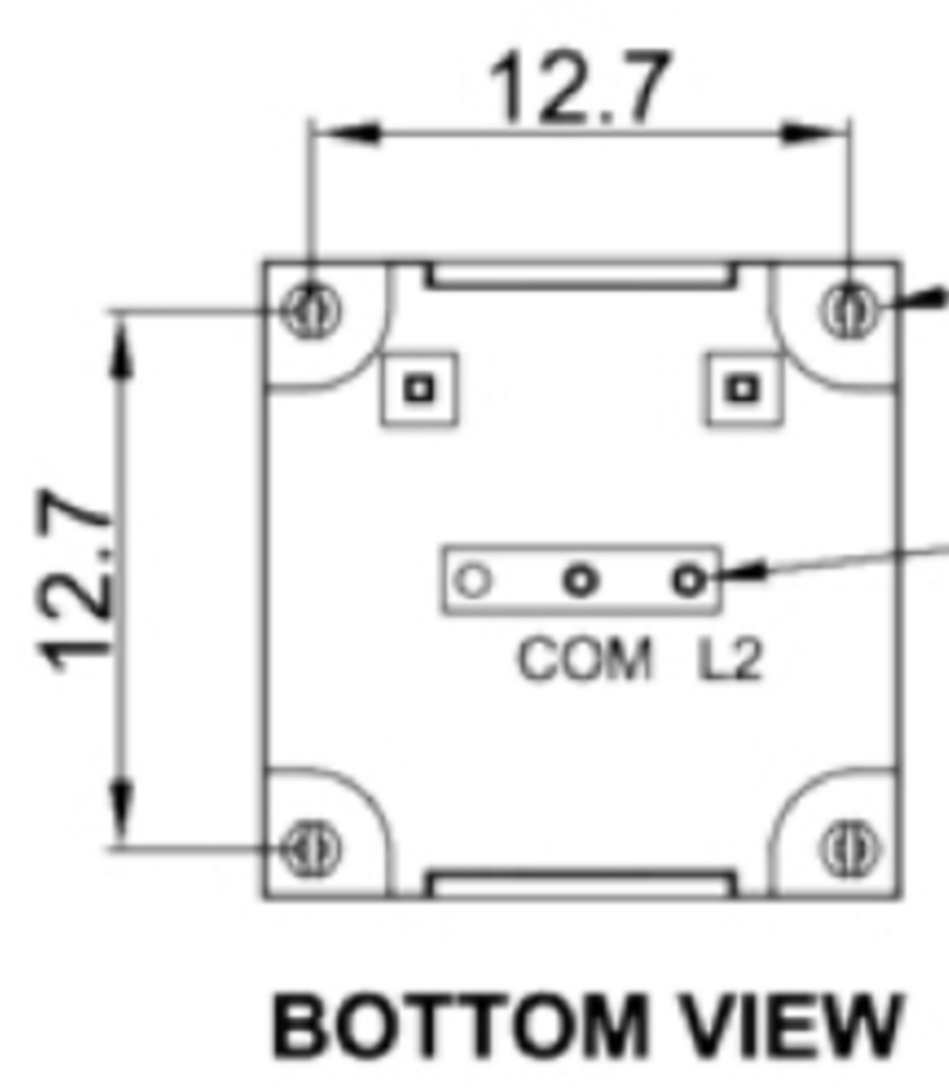
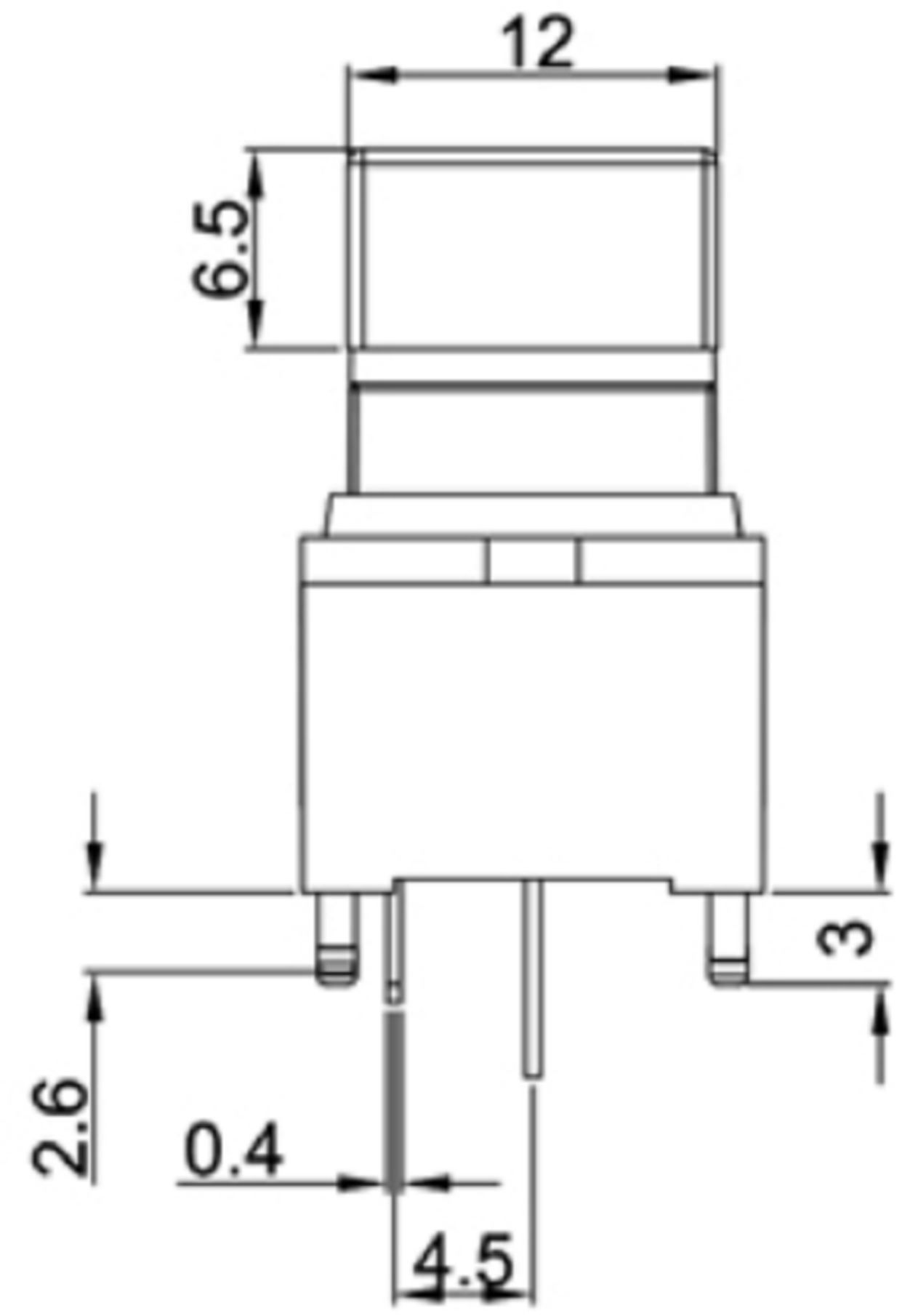
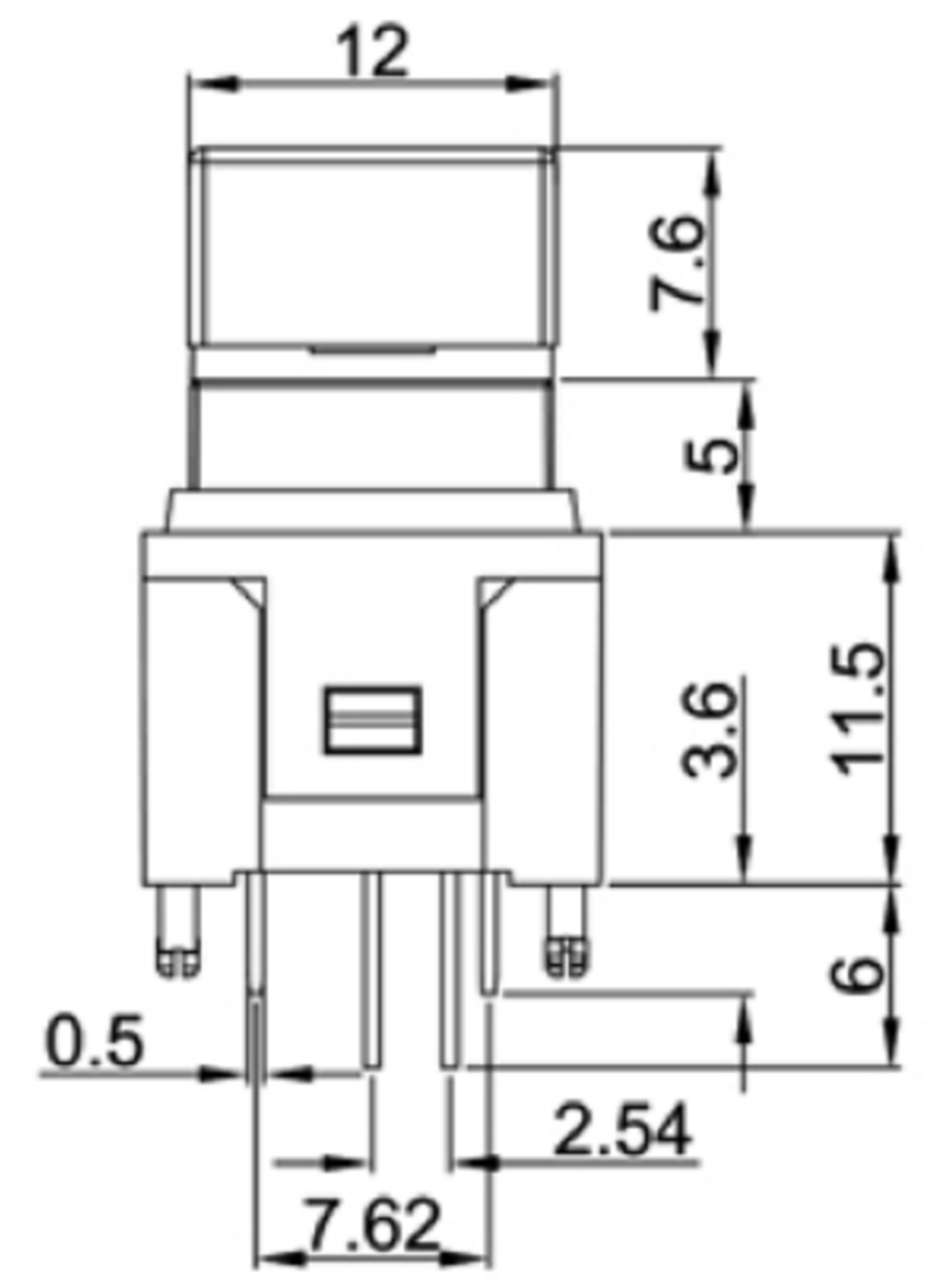

BOTTOM VIEW

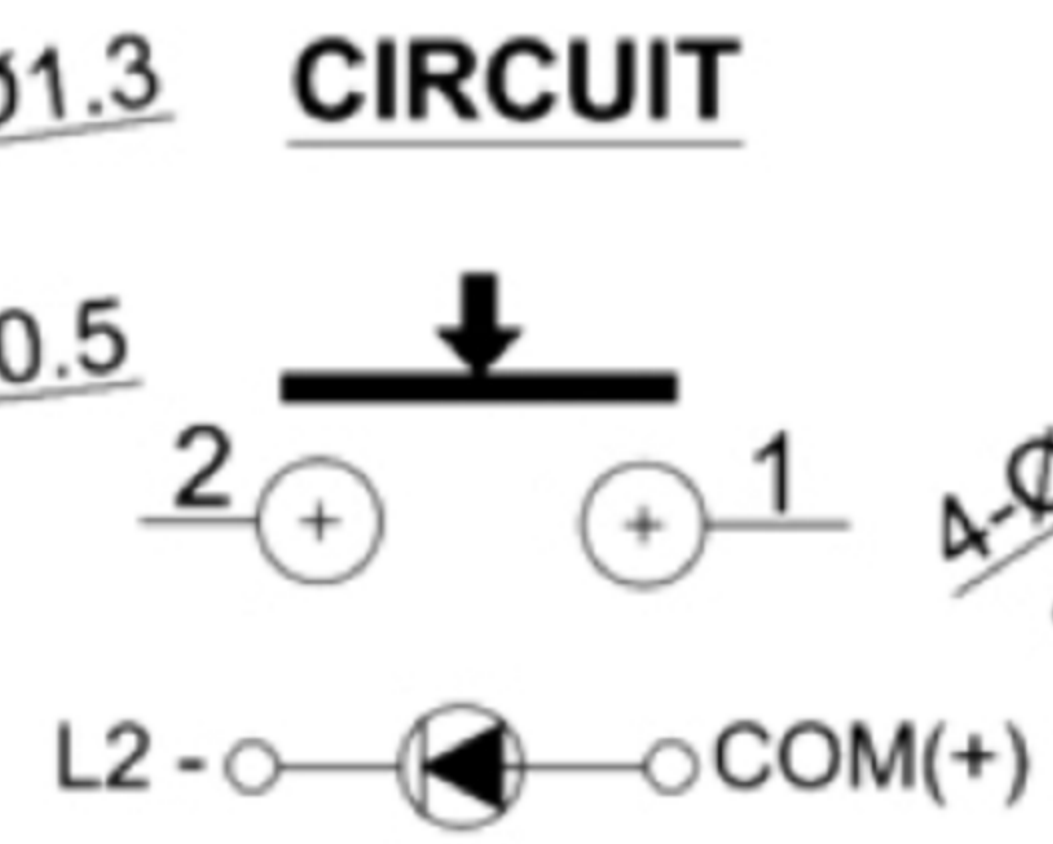

CIRCUIT

P.C.B. LAYOUT

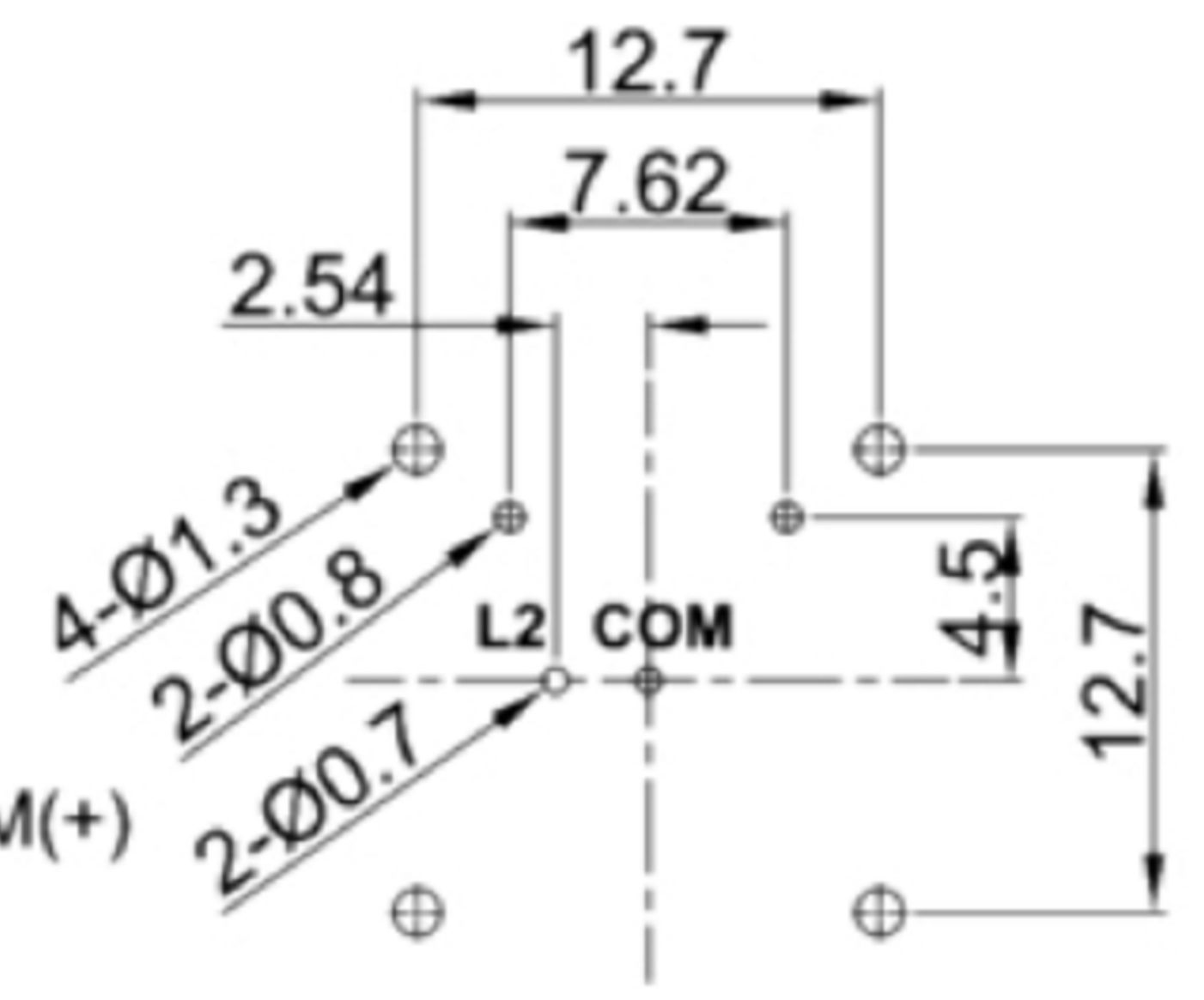

广东科斯达电子科技有限公司
 GUANG DONG KE SI DA ELECTRONIC TECHNOLOGY CO., LTD.

TOLERANCE UNLESS OTHERWISE STATED:	Up to 5 ±0.2	Above 5 ~ 15 ±0.3	Above 15 ~ 30 ±0.4	Above 30 ~ 50 ±0.5	Angle ±0.3	3RD. ANGEL'S	UNITS	MM
------------------------------------	--------------	-------------------	--------------------	--------------------	------------	--------------	-------	----

DRAWN BY:	DATE	MAT'L	TITLE	SWITCH
Jack Lu	12/27/22		MODLE	TACT SWITCH WITH LED
CHECKED BY:	DATE	FINISH	DWG NO.	
Jacky Chen	12/27/22		SHEET NO.	1 of 1
APPROVED BY:	DATE	SCALE	PART NO.	
Tony Kao	12/27/22	1 : 1		

ITEM NO.	DESCRIPTION	DRAWN	DATE

SIZE	A4
VER	R