

SPECIFICATIONS:

Circuit	:SPDT
Rating	:0.4VA 28VDC
Contact resistance	:100mΩ Max.
Insulation resistance	:DC 500V 100MΩ Min.
Withstand voltage	:AC 500V for 1 minute;
Operating force	:200±100gf ;
Total travel	:2.2±0.5mm
Mechanical life	:Over 200,000 cycles;
Electrical life	:Over 100,000 cycles;
Manual welding	:350° C for 3 seconds
Operating temperature	:-25° C ~ +70° C

MATERIAL:

Base:PA+GF,UL rated:94 V-2 Min.
 Cap:PC
 Terminal:Brass, Golden plated;

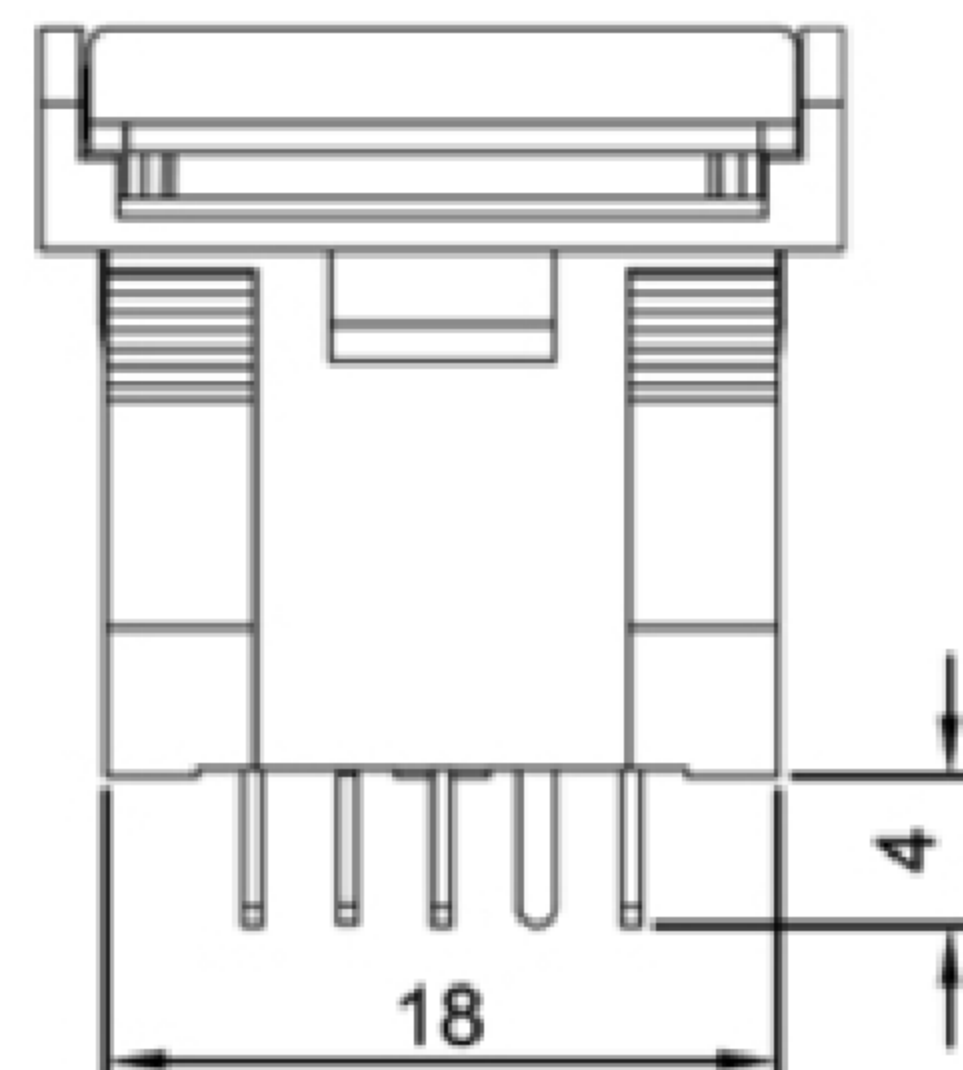
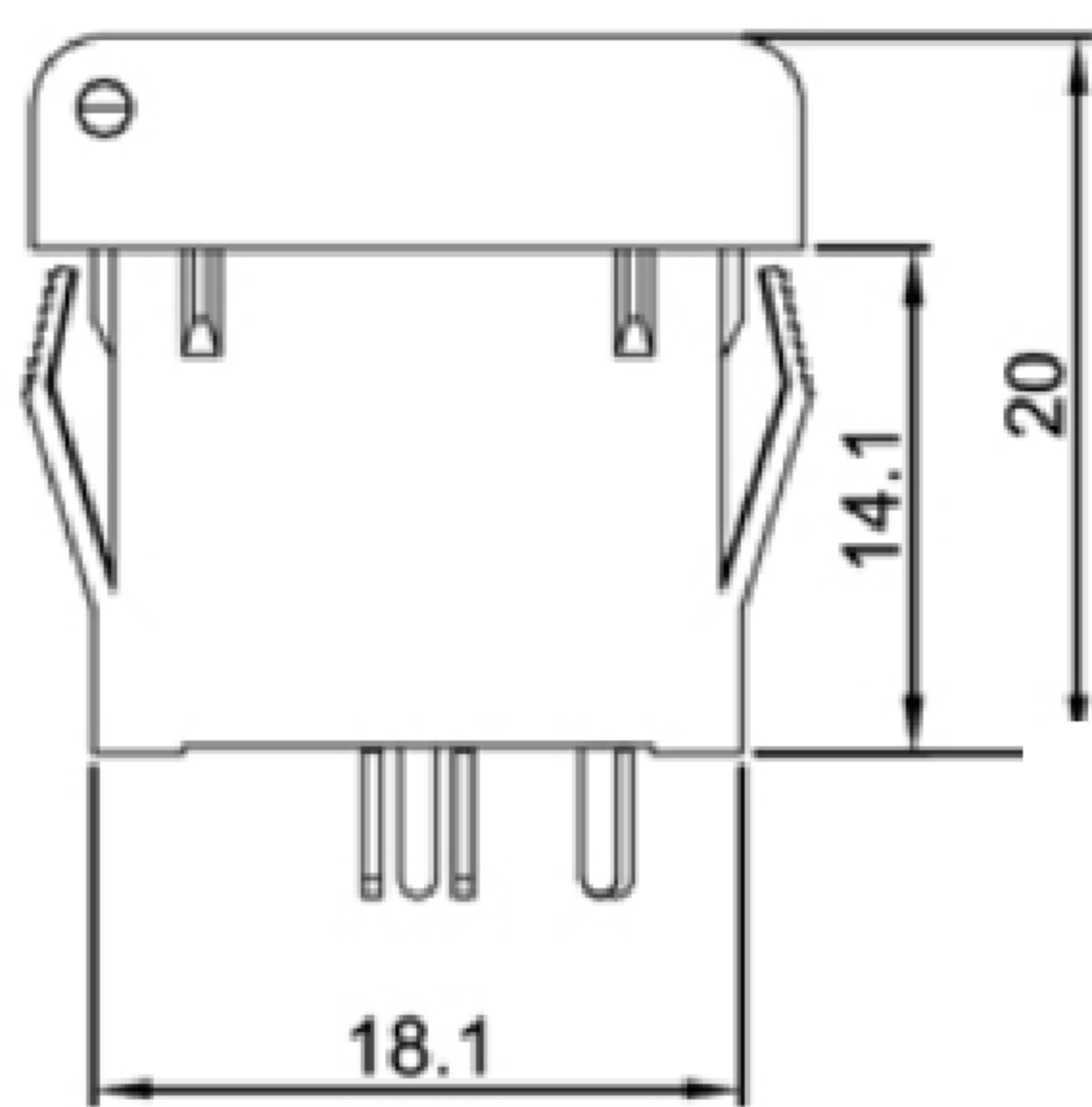

CIRCUIT

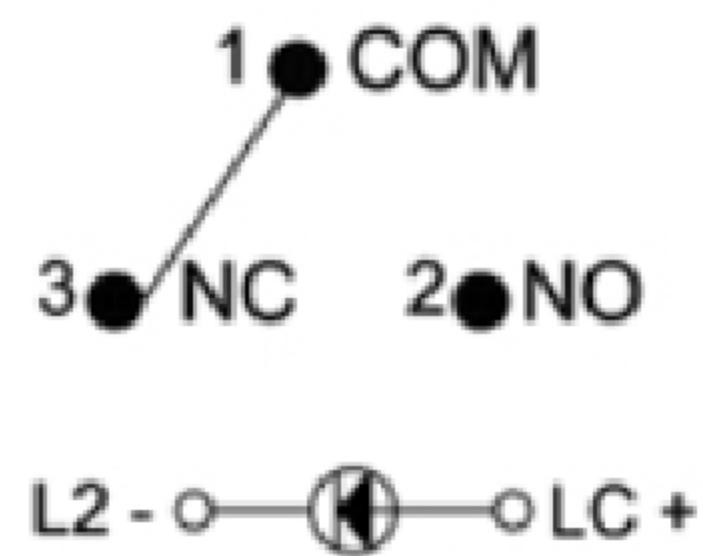

CUT-OUT

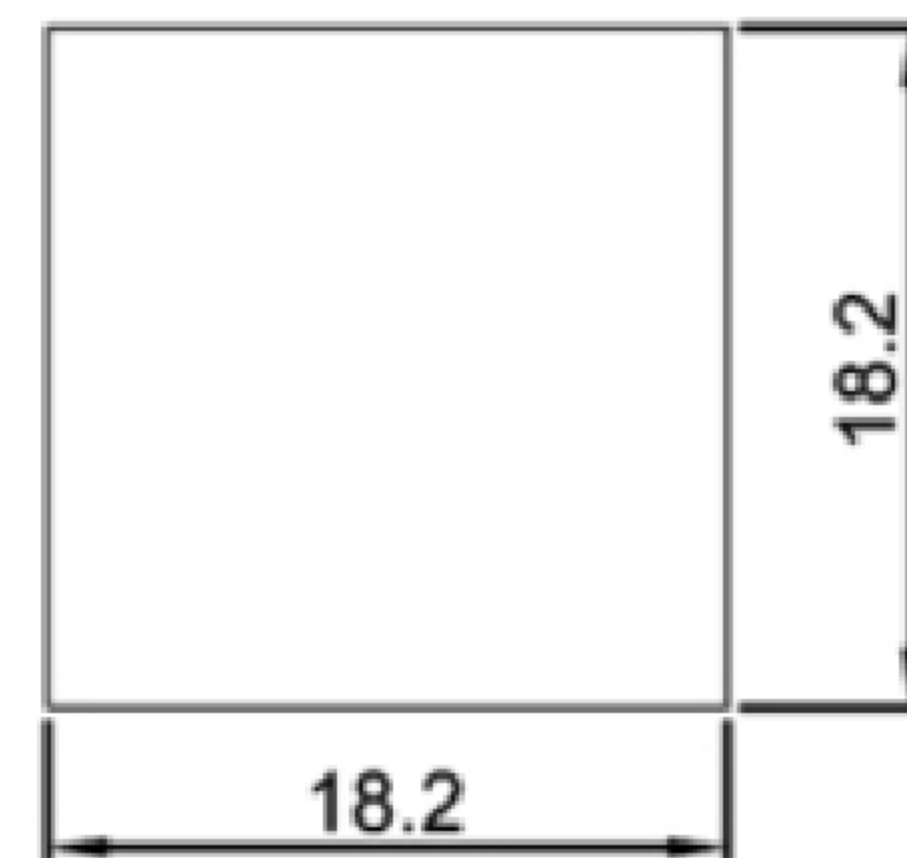

T	Transparence透明	LED SPECIFICATIONS				
B	Black 黑色	W 普通白色	2.9	-	3.6	25
G	Green 绿色	U 普通蓝色	2.7	3.3	3.7	25
U	Blue 蓝色	O 普通橙色	1.75	-	2.35	25
Y	Yellow 黄色	R 红色	1.75	-	2.35	25
R	Red 红色	G 翠绿色	2.7	3.3	3.7	25
Cap Color (X) 上盖颜色 (X)		Clip emitted color (Y) 灯的发光颜色 (Y)	最小	一般	最大	最大操作电流 (mA)
			顺向电压(V)			

广东科斯达电子科技有限公司
 GUANG DONG KE SI DA ELECTRONIC TECHNOLOGY CO., LTD.

TOLERANCE UNLESS OTHERWISE STATED:
 Up to 5 ±0.2
 Above 5 ~ 15 ±0.3
 Above 15 ~ 30 ±0.4
 Above 30 ~ 50 ±0.5
 Angle ±0.3

3RD. ANGEL'S

UNITS MM

DRAWN BY:	DATE	MAT'L	TITLE	SWITCH
Jack Lu	12/27/22			
CHECKED BY:	DATE	FINISH	MODLE	TACT SWITCH WITH LED
Jacky Chen	12/27/22			
APPROVED BY:	DATE	SCALE	DWG NO.	SIZE
Tony Kao	12/27/22	1:1		A4
		SHEET NO.	PART NO.	VER
		1 of 1		R