

# PTM19

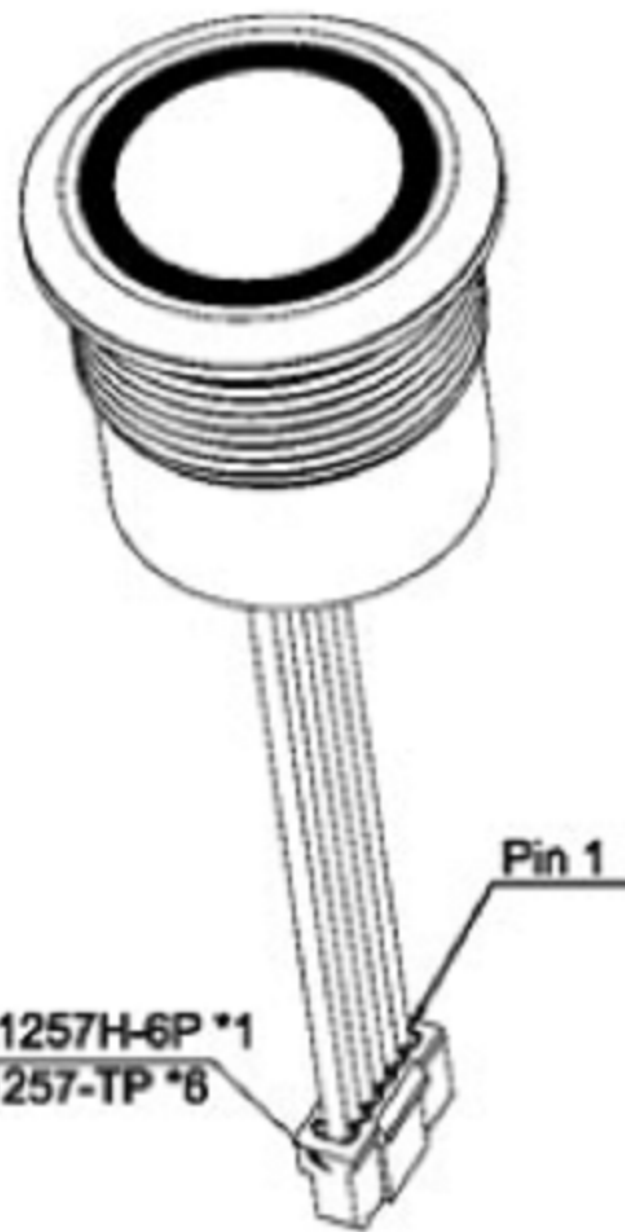

Housing: CJT, A1257H-6P \*1  
Terminal: CJT, 1257-TP \*6

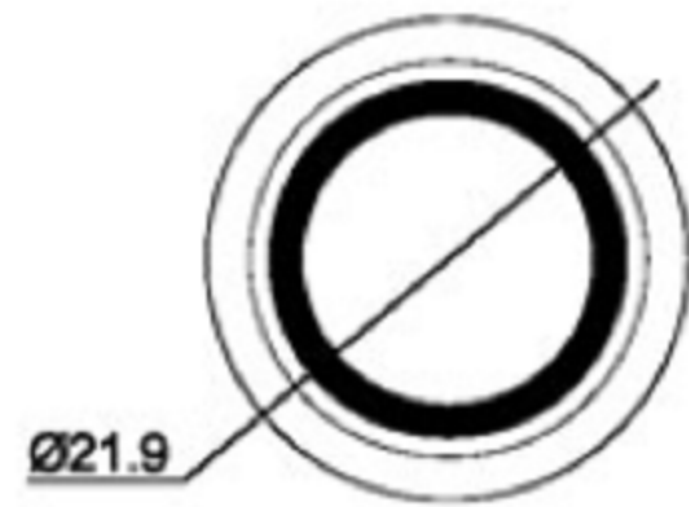
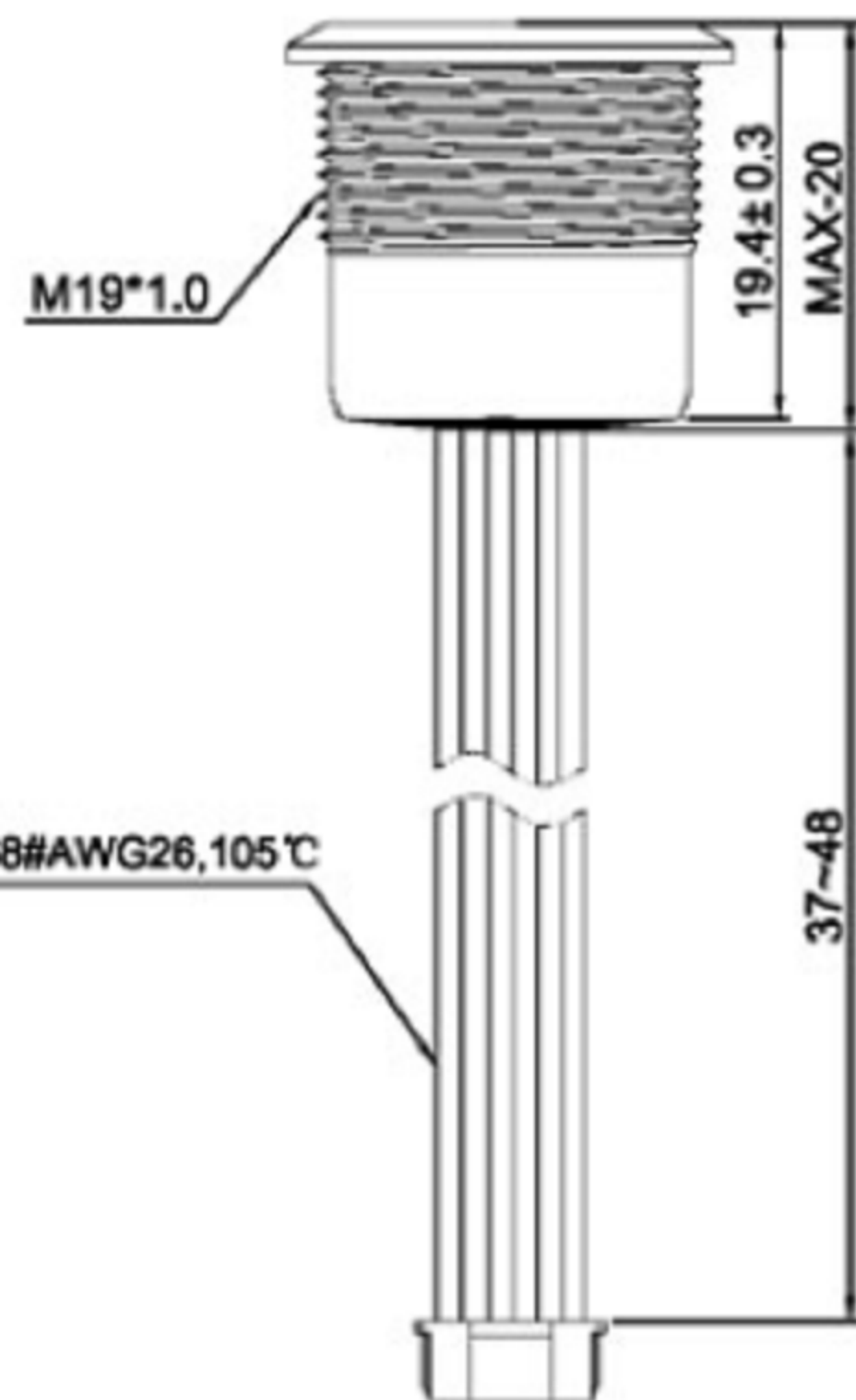

## SPECIFICATIONS



Rating: 1 to 50mA ;  
3 to 24VDC ;  
Degree of protection: IEC IP67;  
Contact Resistance: 100mΩ Max. ;  
Dielectric Strength: 250 VAC For 1 minute ;  
Insulation resistance: 100M Ω Min;  
Total Travel: 0.8~1.0 mm ;  
Operating Force: 600± 100gf ;  
Operating life: 100,000 cycles Min;  
LED Life: 50,000 hours;  
LED Rating: 20mA Max;  
3 to 24VDC ;

### Switch the material:

1. Shell material: Aluminium Alloy;
2. Key: PC;
3. Back shroud: PA66;
4. Supporting plate: POM;

## CIRCUIT

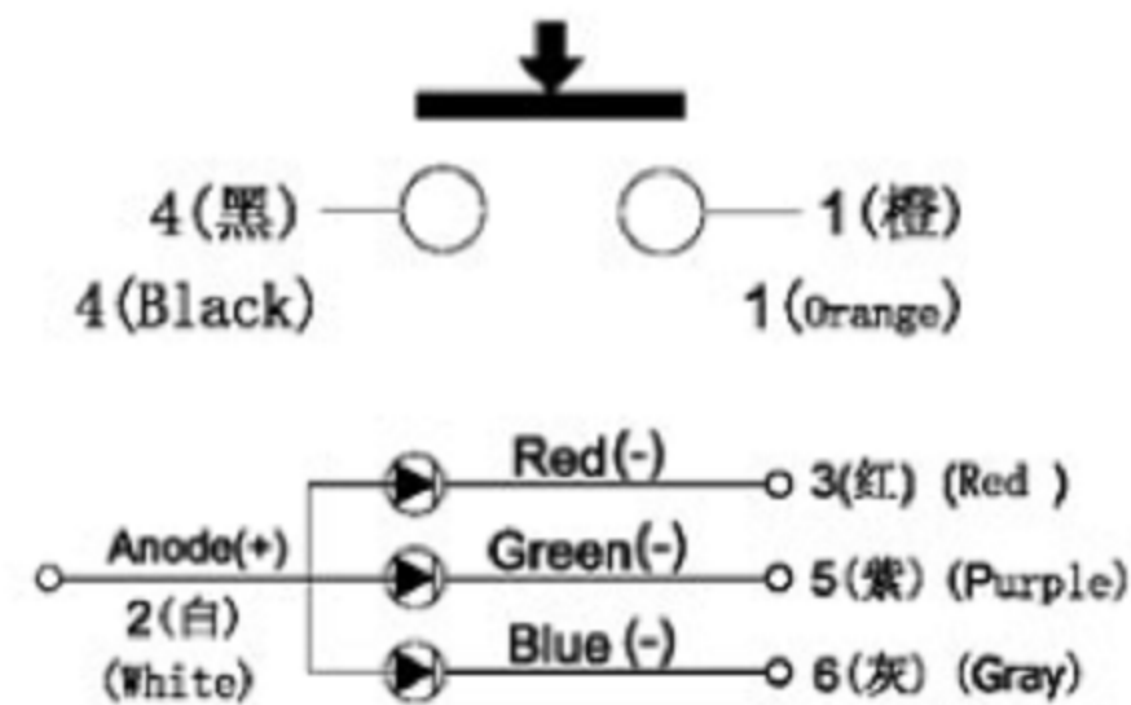

- 1. Orange: Functio
- 2. White: Anode(+)
- 3. Red: Red(-)
- 4. Black: Functio
- 5. Purple: Green(-)
- 6. Gray: Blue(-)

- 6. 灰色: 蓝灯负极
- 5. 紫色: 绿灯负极
- 4. 黑色: 开关功能
- 3. 红色: 红灯负极
- 2. 白色: 共阳极
- 1. 橙色: 开关功能

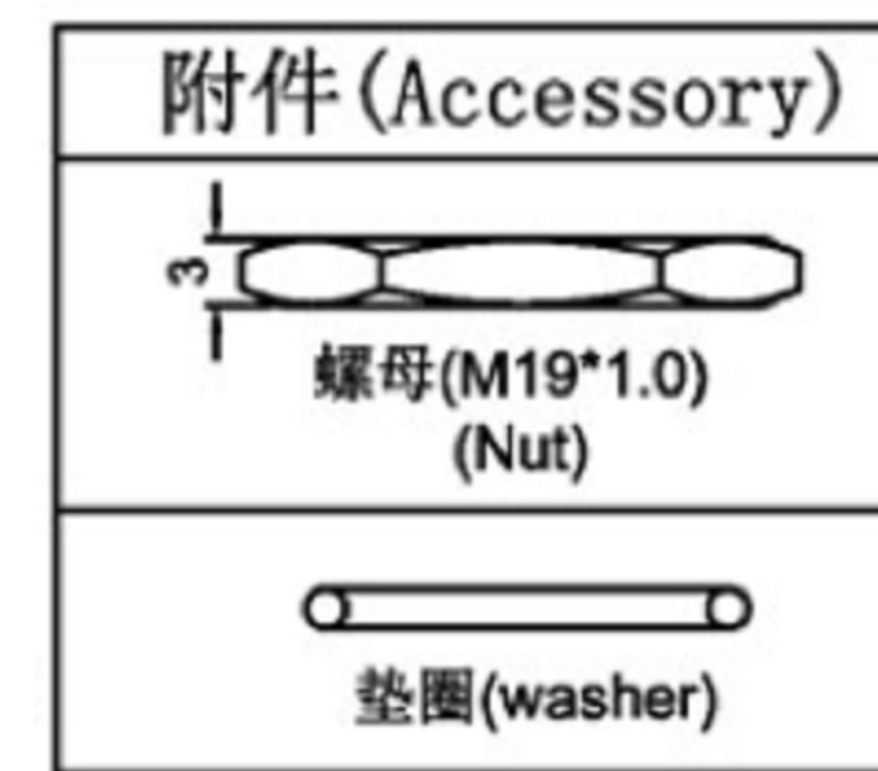

## PAD LAYOUT



广东科斯达电子科技有限公司  
GUANG DONG KE SI DA ELECTRONIC TECHNOLOGY CO., LTD.

TOLERANCE UNLESS OTHERWISE STATED: Up to 5 ±0.2, Above 5 ~ 15 ±0.3, Above 15 ~ 30 ±0.4, Above 30 ~ 50 ±0.5, Angle ±0.3

3RD. ANGEL'S

UNITS MM

DRAWN BY:	DATE	MAT'L	TITLE	SWITCH
Jack Lu	12/27/22		MODLE	TACT SWITCH WITH LED
CHECKED BY:	DATE	FINISH	DWG NO.	SIZE
Jacky Chen	12/27/22			A4
APPROVED BY:	DATE	SCALE	PART NO.	VER
Tony Kao	12/27/22	1:1		R
		SHEET NO.		
		1 of 1		