

Rating: 20A 125V AC  
 22A 250V AC (ENEC CB CQC)  
 Contact Resistance: 50mΩ Max  
 Insulation Resistance: DC 500V 100MΩ Min.  
 Dielectric Strength: AC1500V 1 minute  
 Operating Force: 650±150gf  
 Mechanical Life: Over 30,000 cycles  
 Electrical Life: Over 10,000 cycles  
 Operating Temperature: 0 C~85 C

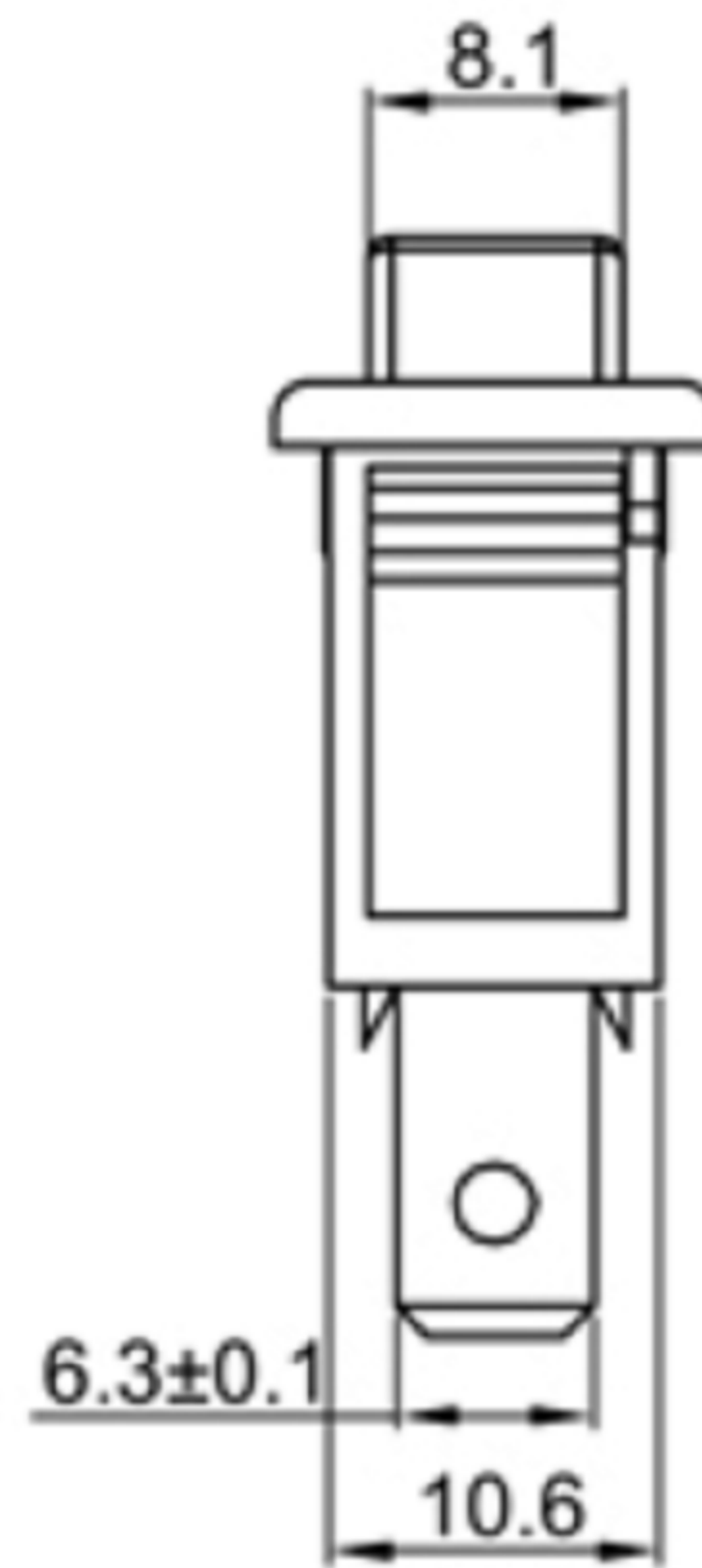

**CUT-OUT**

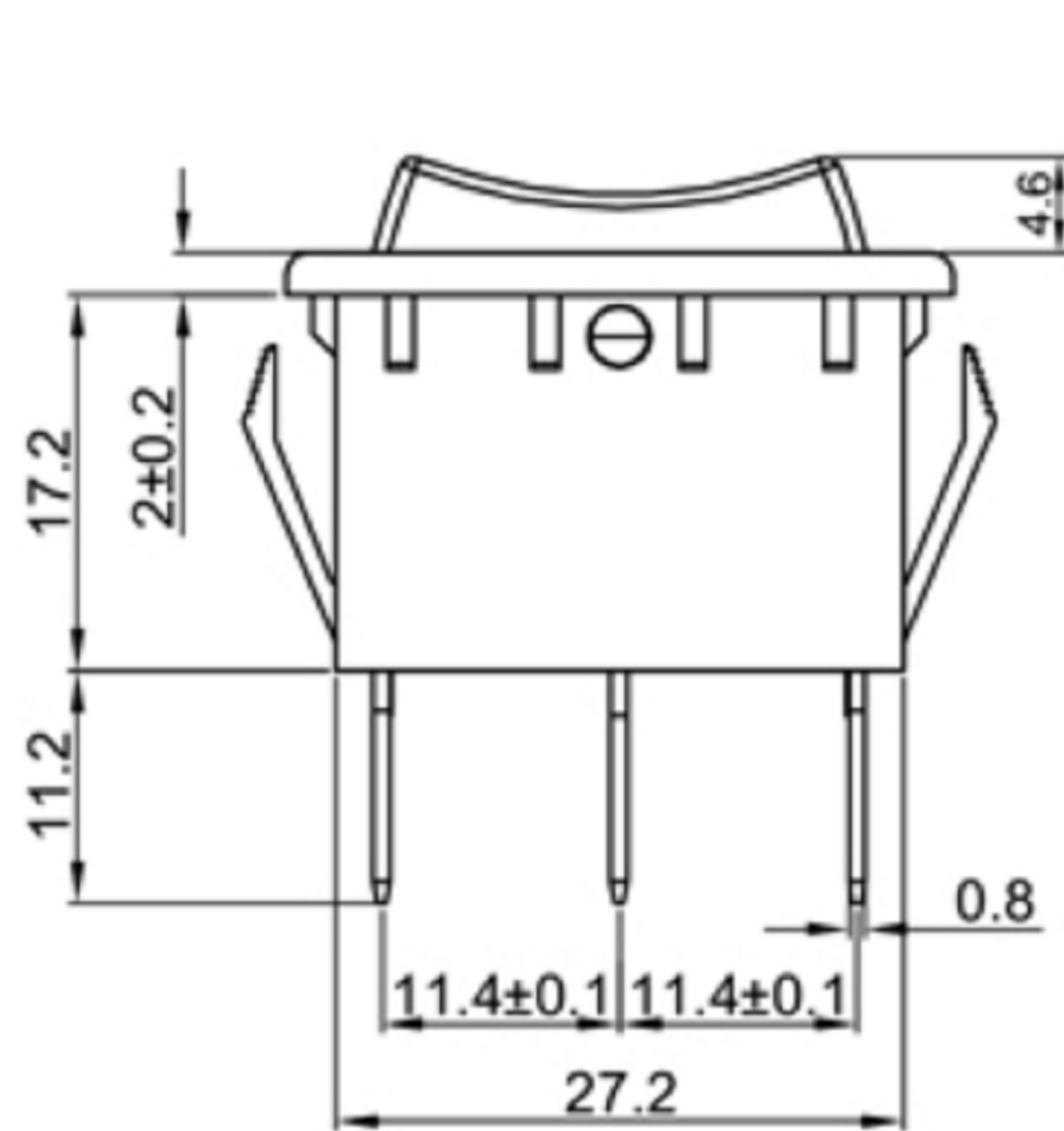
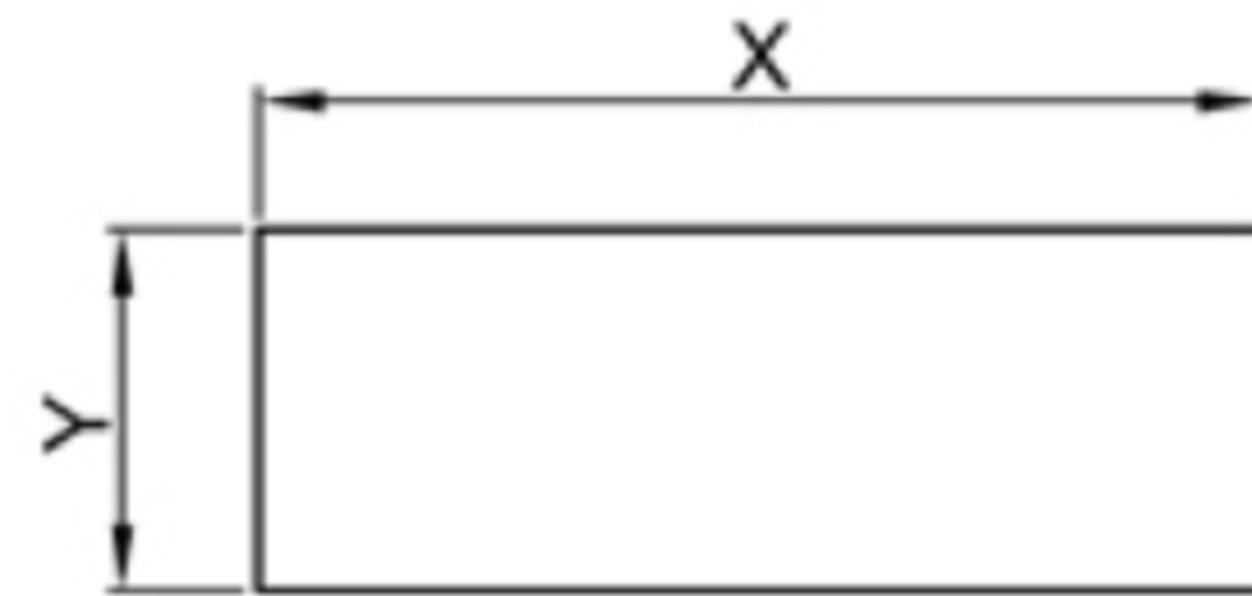

	X	Y
0.75~1.25	30.0+0.1	11.0+0.1
1.25~2.00	30.2+0.1	11.0+0.1
2.00~3.00	30.4+0.1	11.0+0.1

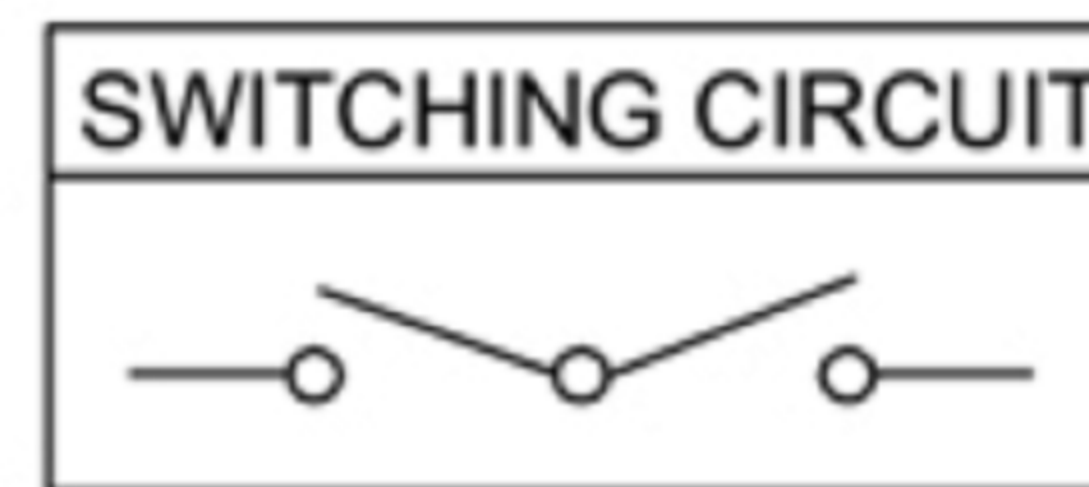

**广东科斯达电子科技有限公司**  
 GUANG DONG KE SI DA ELECTRONIC TECHNOLOGY CO., LTD.

TOLERANCE UNLESS OTHERWISE STATED:  
 Up to 5 ±0.2  
 Above 5 ~ 15 ±0.3  
 Above 15 ~ 30 ±0.4  
 Above 30 ~ 50 ±0.5  
 Angle ±0.3

3RD. ANGEL'S

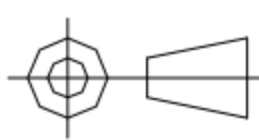

UNITS MM

DRAWN BY:	DATE	MAT'L	TITLE	SWITCH
Jack Lu	12/27/22			
CHECKED BY:	DATE	FINISH	MODLE	TACT SWITCH WITH LED
Jacky Chen	12/27/22			
APPROVED BY:	DATE	SCALE	DWG NO.	SIZE
Tony Kao	12/27/22	1 : 1		A4
		SHEET NO.	PART NO.	VER
		1 of 1		R

ITEM NO.	DESCRIPTION	DRAWN	DATE