

B	Black 黑色
W	White 白色
U	Blue 蓝色
G	Green 绿色
R	Red 红色
Cap Color (X) 上盖颜色 (X)	

SPECIFICATIONS

Circuit	:SPST
Current rating	:50mA /10μA
Voltage rating	:16V DC/1V DC
Dielectric withstanding voltage	:250VAC for 1 minute
Contact resistance	:100m Ω Max. (Initial)
Insulation resistance	:100M Ω Min.
Operating force	:500±80gf
Full travel	:1.0±0.4mm
Life Test:	:100,000 cycles Min
Solder specifications	:260° C for 5 seconds
Operating temperature	:-40° C ~ +90° C

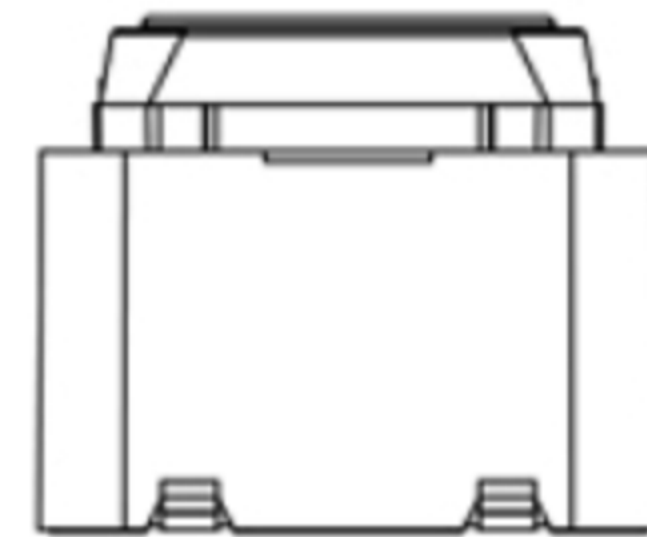
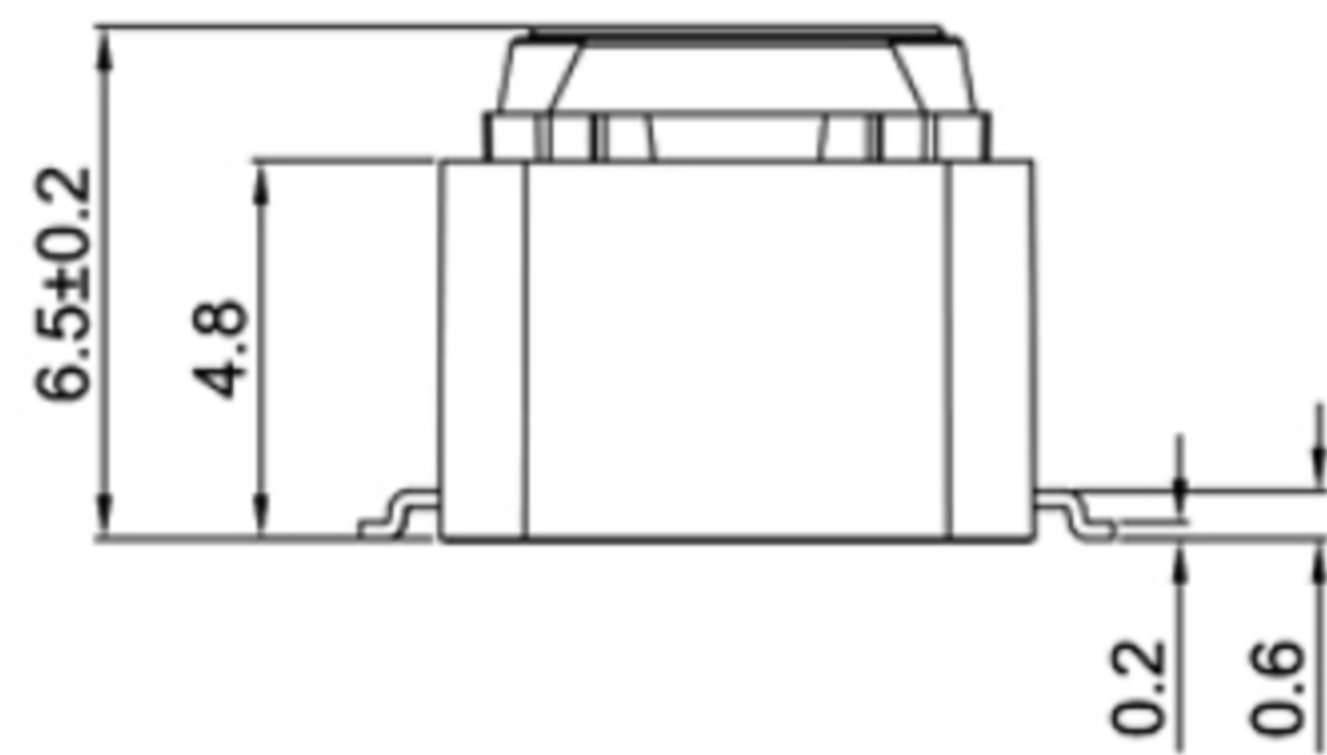

MATERIAL:

Base : PA66+GF,UL rated:94 v-2 Min;
 Cap: PA66+GF,UL rated:94 v-2 Min;
 Terminal: Brass,Silver plated;

CIRCUIT

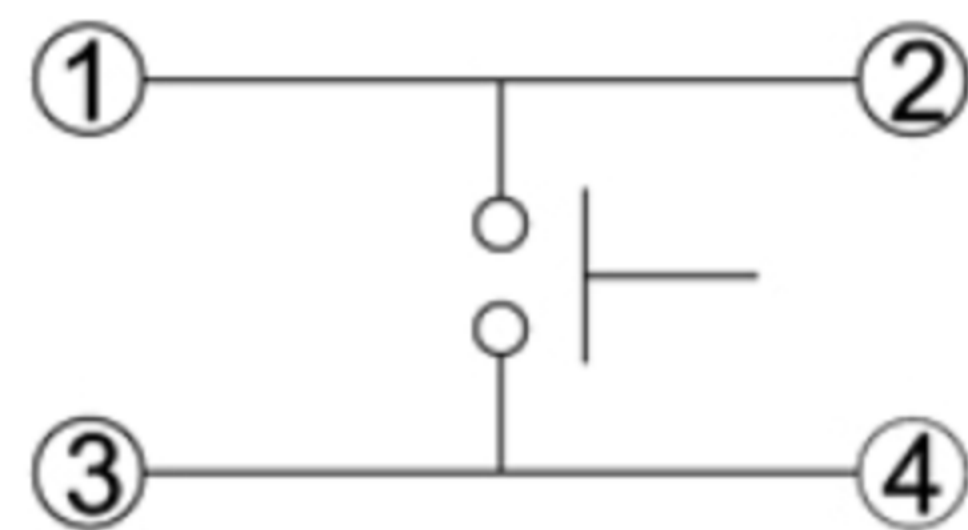

P.C.B. LAYOUT

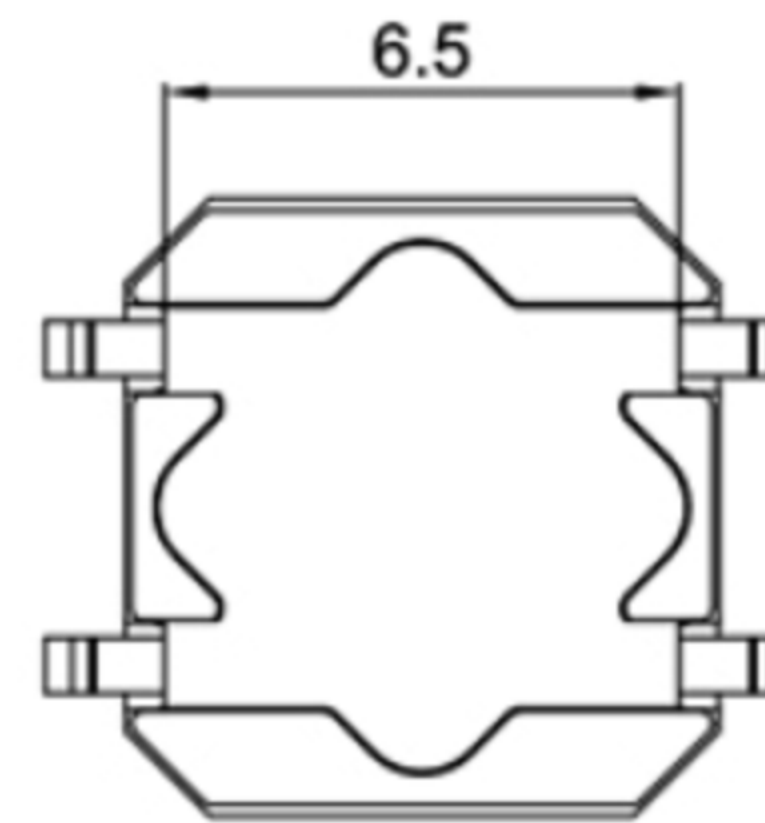
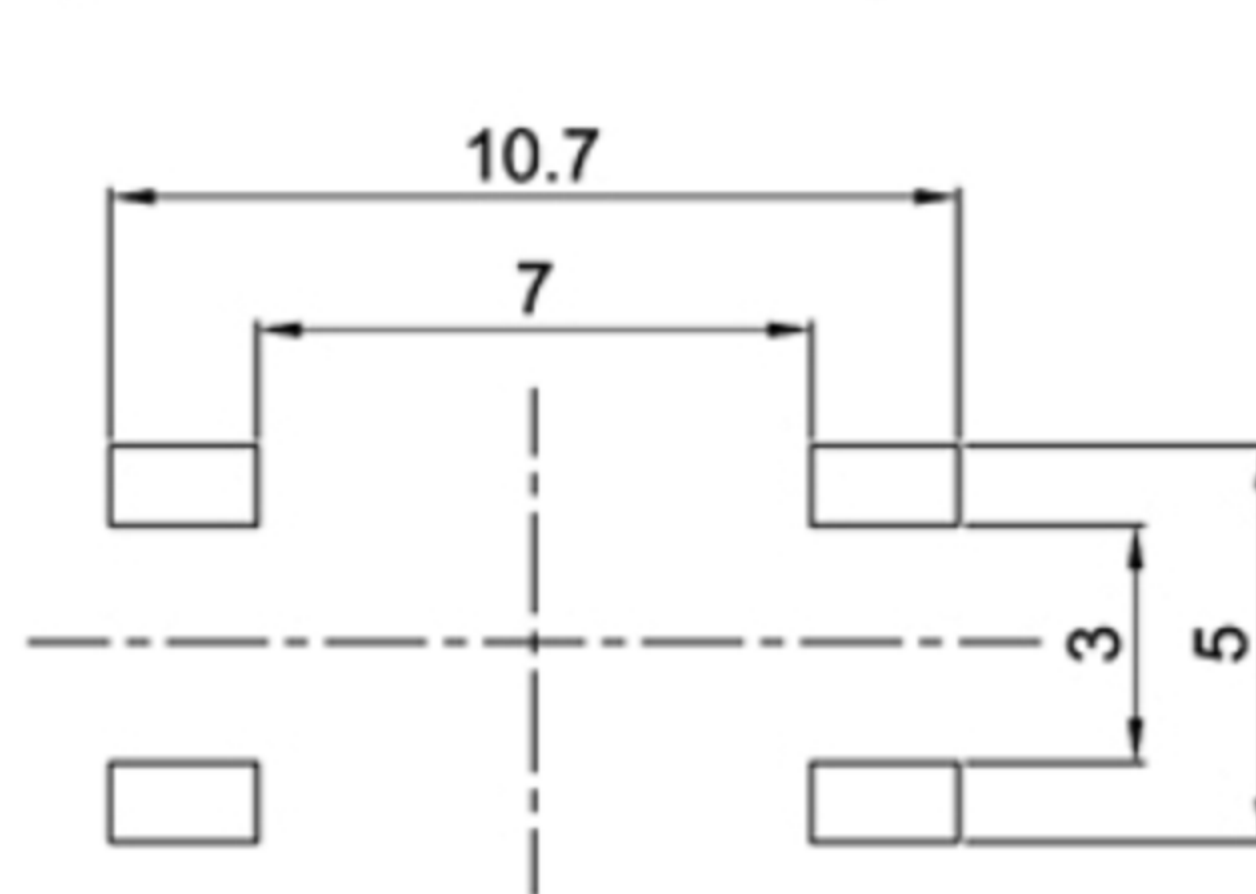

NO.	DESCRIPTION	QTY	MATERIAL	PLATING
7	CAP	1	ABS / PC	Black
6	LED	1		
5	FIXITY	1	PA66	Black
4	CONTACT	1	PHOSPHOR BRONZE	Ag plated
3	TERMINAL	2	BRASS	Ag plated
2	CASE	1	PA66	Black
1	KNOB	1	PA66	Black/White



广东科斯达电子科技有限公司
GUANG DONG KE SI DA ELECTRONIC TECHNOLOGY CO., LTD.

TOLERANCE UNLESS OTHERWISE STATED:
 Up to 5 ±0.2
 Above 5 ~ 15 ±0.3
 Above 15 ~ 30 ±0.4
 Above 30 ~ 50 ±0.5
 Angle ±0.3

3RD. ANGEL'S

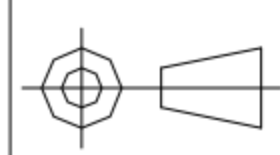

UNITS MM

DRAWN BY: Jack Lu
 CHECKED BY: Jacky Chen
 APPROVED BY: Tony Kao

DATE: 12/27/22
 DATE: 12/27/22
 DATE: 12/27/22

MAT'L
 FINISH
 SCALE: 1:1
 SHEET NO.: 1 of 1
 TITLE: SWITCH
 MODLE: TACT SWITCH WITH LED
 DWG NO.
 PART NO.

SIZE: A4
 VER: R

ITEM NO.	DESCRIPTION	DRAWN	DATE