

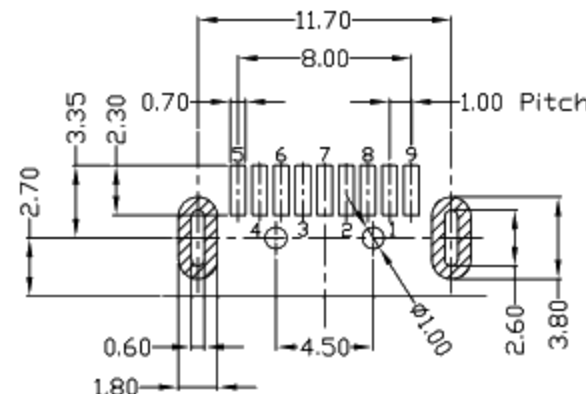

RoHS
Compliant
2002/95/EC

REV	LTR	DESCRIPTION	DATE	REVISER	APPD

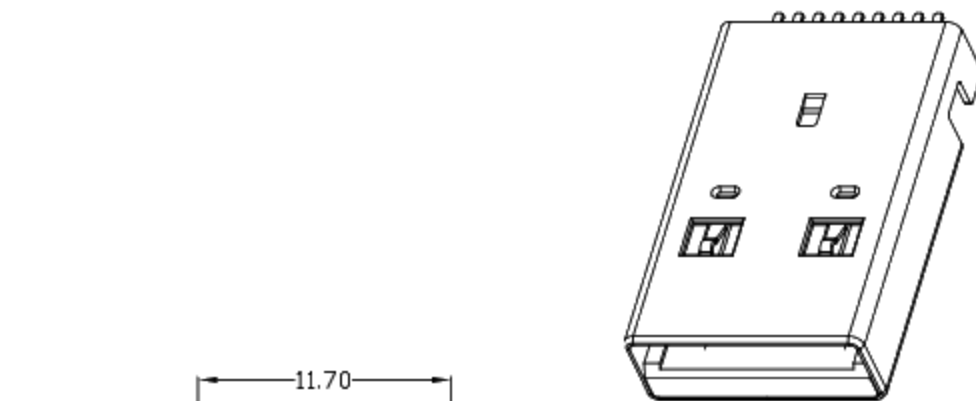
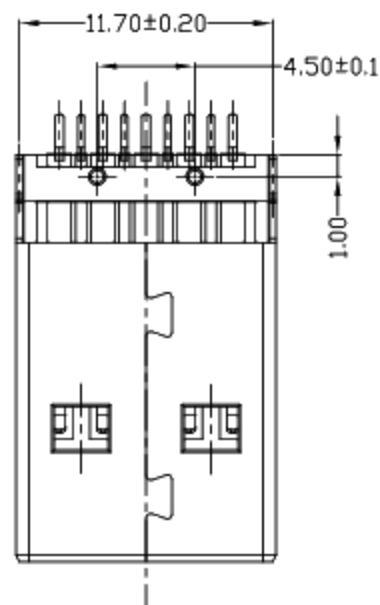
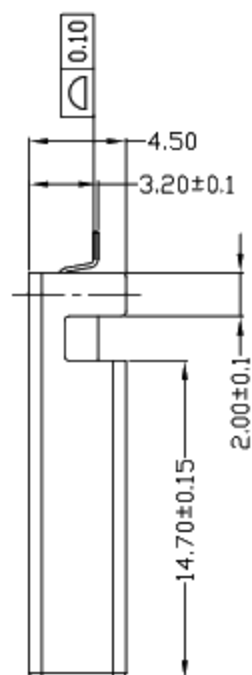
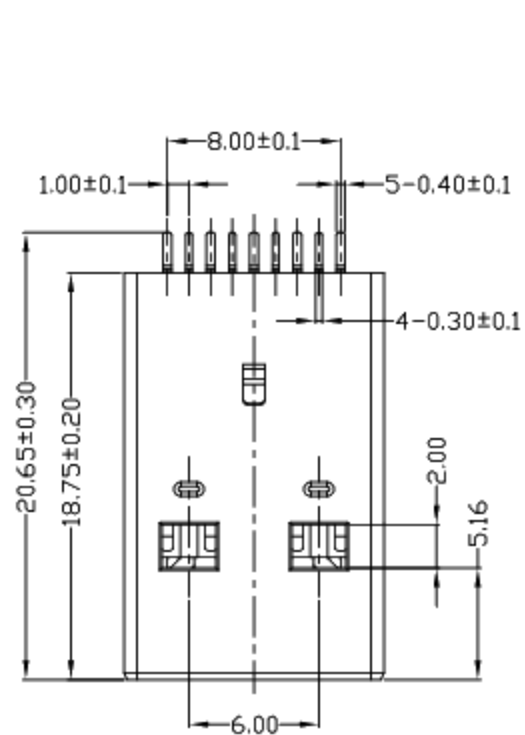

RECOMMENDED P.C.B LAYOUT

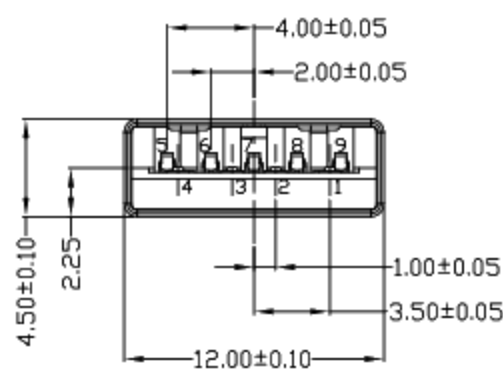

- NOTES:
- ELECTRICAL:
 - VOLTAGE CURRENT RATING: 1.5AMP, 30V AC;
 - INSULATION RESISTANCE: 100MΩ MIN;
 - CONTACT RESISTANCE: 30mΩ MAX;
 - WITHSTANDING VOLTAGE: 500V AC;
 - OPERATING TEMPERATURE: -55°C TO +85°C.
 - Mechanical:
 - Mating Force: 35N MAX
 - Unmating Force: 10N MIN.
 - DIMENSIONS MARKED *▼* TO BE CHECKED BY Q.C & IPQC.

4. PART NO.

- 1Au 10*
- 5Au 15U*
- 6Au 30U*
- W: WHITE
- B: BLACK
- BL: BLUE
- 1PBT
- 2PA6T
- 3PA9T
- 4LCP

Bill of materials:

NO	PARTS	MATERIAL	QTY	FINISHING	UNITS	mm	廣東科斯達電子科技有限公司				
3	HOUSING	LCP+30%GF	1	PLATED NICKEL	X. ±0.35	X.* ±2*	SEE NOTE	TITLE: USB AM 3.0 I=18.7MM 沉板3.2MM 有柱(外壳脚长4.50MM) 锡脚1.9 DR: Ricky 2019/2/18 CHKD: Ricky 2019/2/18 APPD:			
2	SHELL	SPCC	1	UL94V-0	.X ±0.3	.X* ±1*					
1	TERMINAL	COPPER ALLOY	9	PLATED GOLD/TIN	.XX ±0.25	.XX*					
					.XXX ±0.15	.XXX*	Q'TY	SCALE	SHEET	REV.	CUSTOMER DRAWING
								1:1	1/1	B	

THESE DRAWINGS AND SPECIFICATIONS ARE THE PROPERTY OF ACCURATE INNOTECH INC. AND SHALL NOT BE REPRODUCED, COPIED OR USED IN ANY MANNER WITHOUT THE PRIOR WRITTEN CONSENT OF ACCURATE INNOTECH INC.

