

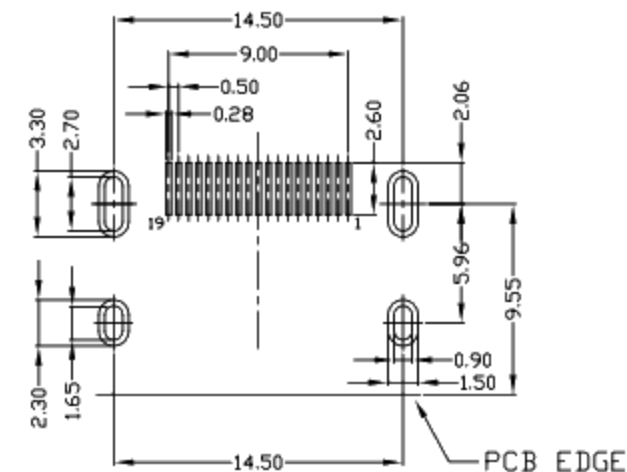

RoHS
Compliant
2002/95/EC

Halogen Free

REV.	ECN. NO.	APPD.

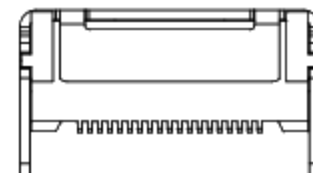
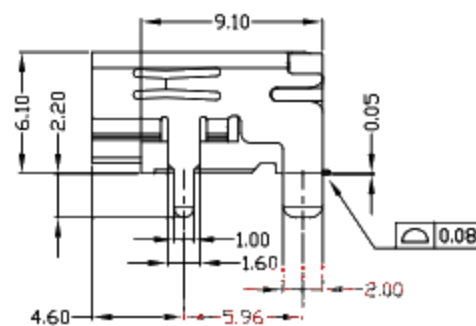
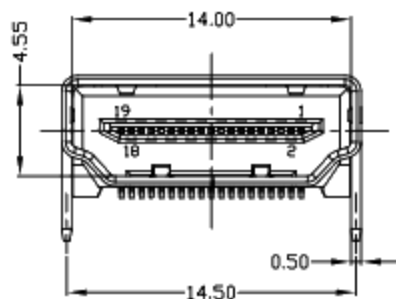
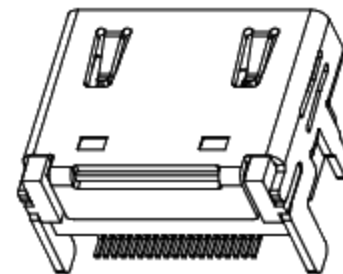
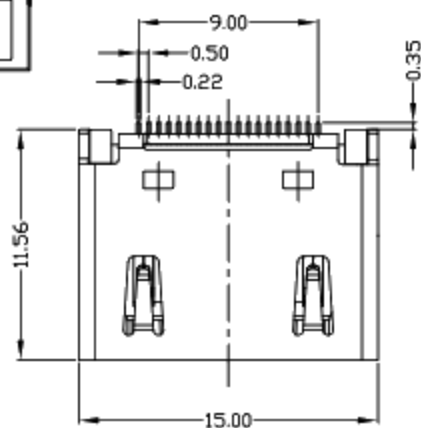

RECOMMENDED PCB LAYOUT (T=1.60mm)

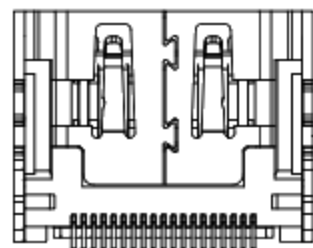

NOTES:

- ELECTRICAL:
 - VOLTAGE CURRENT RATING: 0.5AMP,30V AC;
 - INSULATION RESISTANCE: 1000MΩ MIN;
 - CONTACT RESISTANCE: 30mΩ MAX;
 - WITHSTANDING VOLTAGE: 500V AC;
 - OPERATING TEMPERATURE:-20°C TO +85°C.
- Mechanical:
 - Mating Force: 35N MAX
 - Unmating Force: 10N MIN.
- DIMENSIONS MARKED '▼' TO BE CHECKED BY Q.C & IPQC.

4.PART NO.

Ni: Ni
G: Au
1: Au 1U*
5: Au 15U*

Bill of materials:

NO	PARTS	MATERIAL	QTY	FINISHING	UNITS	mm	廣東科斯達電子科技有限公司				
3	HOUSING	LCP+30%GF	1	UL94V-0	X. ±0.35	X.* ±2*	MAT'L	TITLE:		PART NO.:	
2	SHELL	SPCC	1	PLATED NICKEL	.X ±0.3	.X* ±1*	SEE NOTE	DR: gan 2017/07/2		DWG NO.:	
1	TERMINAL	COPPER ALLOY	19	PLATED GOLD/TIN	.XXX ±0.15	.XXX*	FINISH	CHKD: gan 2017/07/2		SCALE SHEET REV. CUSTOMER DRAWING	
							SEE NOTE	APPD:		1:1 1/1 B	

THESE DRAWINGS AND SPECIFICATIONS ARE THE PROPERTY OF ACCURATE INNOTECH INC AND SHALL NOT BE REPRODUCED, COPIED OR USED IN ANY MANNER WITHOUT THE PRIOR WRITTEN CONSENT OF ACCURATE INNOTECH INC.

