

RoHS Compliant

NOTES:

1. ELECTRICAL:

- 1) VOLTAGE CURRENT RATING: 1.8AMP, 30V AC;
- 2) INSULATION RESISTANCE: 100MΩ MIN;
- 3) CONTACT RESISTANCE:
30mΩ MAX; INITIAL FOR VBUS AND GND CONTACTS.
50mΩ MAX; INITIAL FOR ALL OTHER CONTACTS.
- 4) WITHSTANDING VOLTAGE: 100V AC;
- 5) OPERATING TEMPERATURE: -55°C TO +85°C.

2. Mechanical:

- 1) Mating Force: 35N MAX
- 2) Unmating Force: 10N MIN.
- 3) Durability: 1,500 cycles

3. DIMENSIONS MARKED '▼'
TO BE CHECKED BY Q.C & IPQC.

4. PART NO.

1: Au 1U*
5: Au 15U*
6: Au 30U*

W: WHITE
B: BLACK
BL: BLUE

1: PBT
2: PA6T
3: PA9T
4: LCP

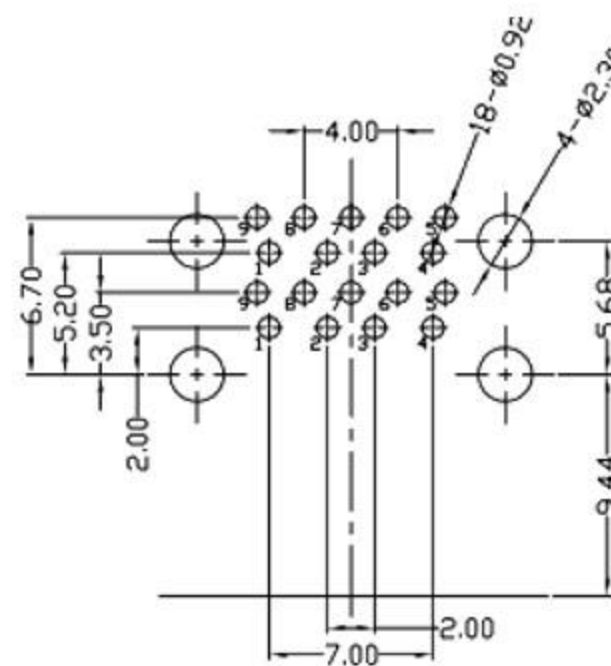
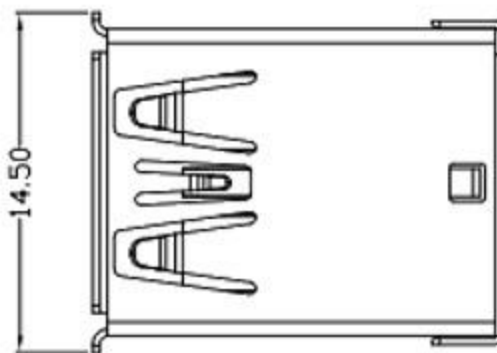
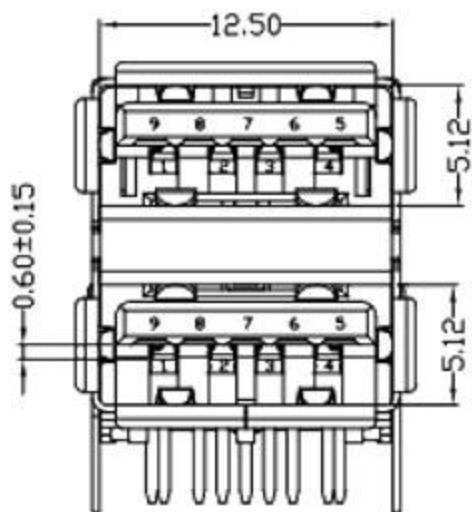
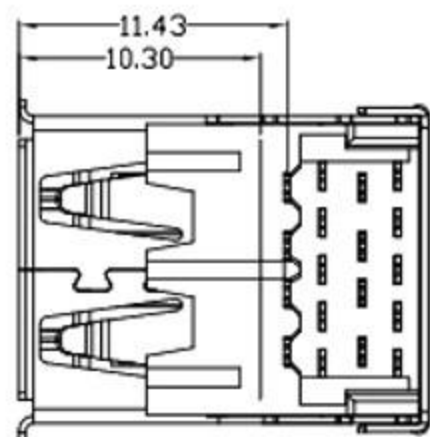
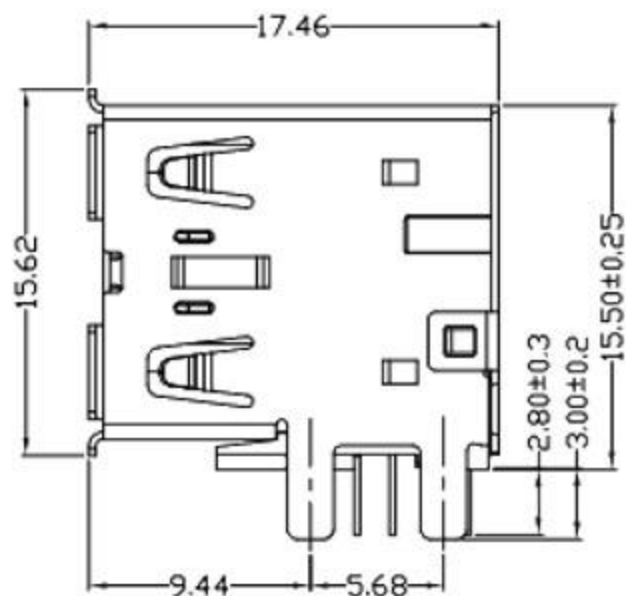

RECOMMEND P.C.B. LAYOUT

PIN ASSIGNMENT:

PIN NO.	1	2	3	4	5	6	7	8	9
	10	11	12	13	14	15	16	17	18
Signal Name	VBUS	D-	D+	GND	STDA_SSRX-	STDA_SSRX+	GND_DRAIN	STDA_SSTX-	STDA_SSTX+
Remark	USB2 Contact Pin				USB3 Contact Pin				

NO.	PART NAME	QTY	MATERIAL	DESCRIPTION	REMARK
⑤	MID PLATE	1	STAINLESS STEEL	Au . PLATING.	T=0.15mm
④	SHELL	1	STAINLESS STEEL	Au . PLATING.	T=0.30mm
③	TERMINAL-B	1	TABLE 2:	TABLE 2:	T=0.12mm
②	TERMINAL-A	1	TABLE 2:	TABLE 2:	T=0.12mm
①	INSULATOR	1	HIGH TEMP	Black	

UNLESS OTHERWISE,
GENERAL TOLERANCE:
X.xxx ±0.10
X.xx ±0.20
X.x ±0.30
X. ±0.38
ANGULAR:
X.xx ±1°
X.x ±3°
X. ±5°

廣東科斯達電子科技有限公司

TITLE: USB connector	P/N: Detail See PART NO. LIST
MODEL:	DRAW NO.:
THIRD ANGLE PROJECTION	UNIT: mm
SCALE: 1:1	SIZE: A4
SHEET: 1/1	

JH2016-080	X2	隨工程圖上升版本次	2016.06.15	陳少兵	DESIGN	陳少兵	2016.06.15
JH2016-071	X1	新增規格	2016.06.10	陳少兵	CHECK	鄭小偉	2016.06.15
20151224001	X	NEW DRAWING	2016.05.05	陳少兵	APPROVAL	呂海濤	2016.06.15
ECN NO.	REV.	DESCRIPTION	DATE	CHANGE	APPROVAL	呂海濤	2016.06.15