

RoHS Compliant

NOTES:

- 1.ELECTRICAL:
  - 1)VOLTAGE CURRENT RATING:1.5AMP,30V AC;
  - 2)INSULATION RESISTANCE: 100MΩ MIN;
  - 3)CONTACT RESISTANCE: 30mΩ MAX;
  - 4)WITHSTANDING VOLTAGE: 500V AC;
  - 5)OPERATING TEMPERATURE:-55°C TO +85°C.
- 2.Mechanical:
  - 1)Mating Force: 35N MAX
  - 2)Unmating Force: 10N MIN.
- 3.DIMENSIONS MARKED '▼'  
TO BE CHECKED BY Q.C & IPQC.

4. PART NO.

- 1Au 1U'  
5Au 15U'  
6Au 30U'
- W:WHITE  
B:BLACK  
BL:BLUE
- 1PBT  
2PA6T  
3PA9T  
4LCP

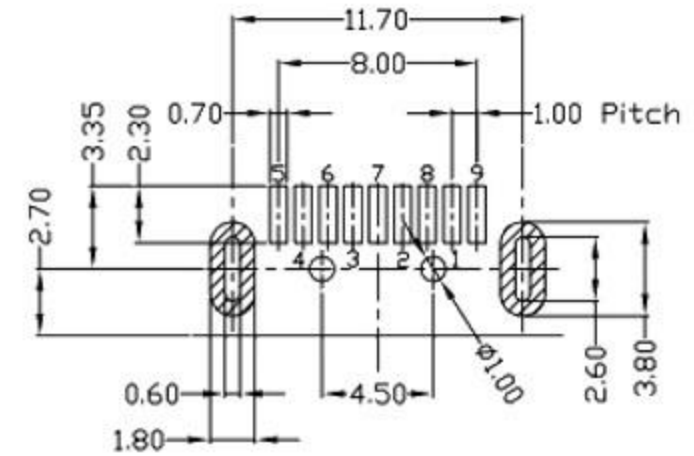
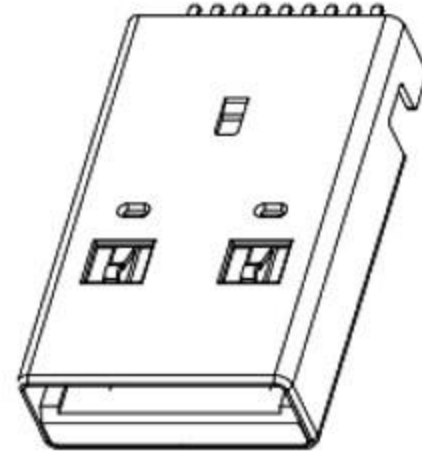
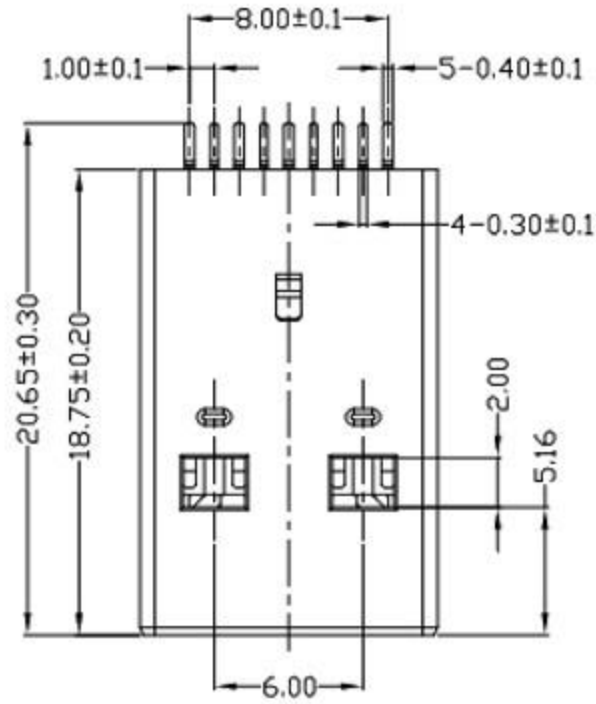

RECOMMENDED P.C.B LAYOUT

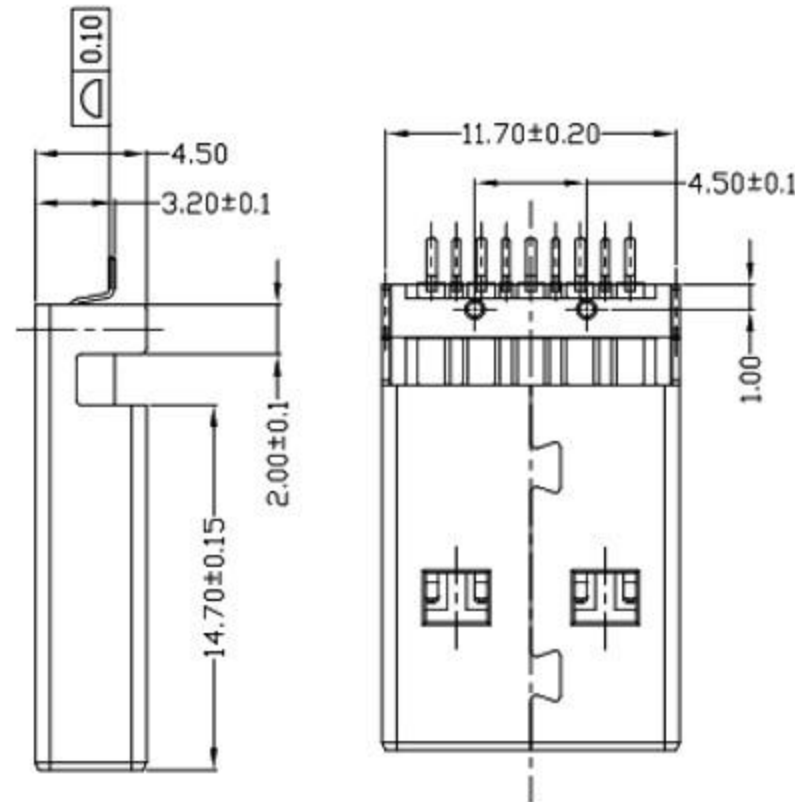
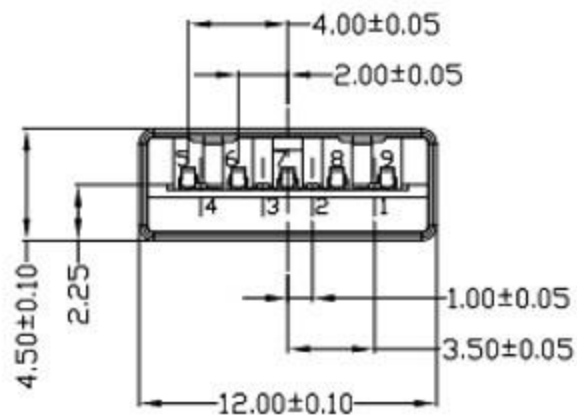

⑤	MID PLATE	1	STAINLESS STEEL	Au . PLATING.	T=0.15mm
④	SHELL	1	STAINLESS STEEL	Au . PLATING.	T=0.30mm
③	TERMINAL-B	1	TABLE 2:	TABLE 2:	T=0.12mm
②	TERMINAL-A	1			T=0.12mm
①	INSULATOR	1	HIGH TEMP	Black	
NO.	PART NAME	QTY	MATERIAL	DESCRIPTION	REMARK

UNLESS OTHERWISE,  
GENERAL TOLERANCE:

- X.xxx ±0.10
- X.xx ±0.20
- X.x ±0.30
- X. ±0.38

ANGULAR:

- X.xx ±1°
- X.x ±3°
- X. ±5°

廣東科斯達電子科技有限公司

TITLE: USB connector  
P/N: Detail See PART NO. LIST  
MODEL:  
DRAW NO.:

THIRD ANGLE PROJECTION UNIT: mm SCALE: 1:1 SIZE: A4 SHEET: 1/1

JH2016-080	X2	隨工程图上升版本次	2016.06.15	陈少兵	DESIGN	陈少兵	2016.06.15
JH2016-071	X1	新增规格	2016.06.10	陈少兵	CHECK	郑小伟	2016.06.15
20151224001	X	NEW DRAWING	2016.05.05	陈少兵	APPROVAL	吕海涛	2016.06.15
ECN NO.	REV.	DESCRIPTION	DATE	CHANGE	APPROVAL		