

RoHS Compliant

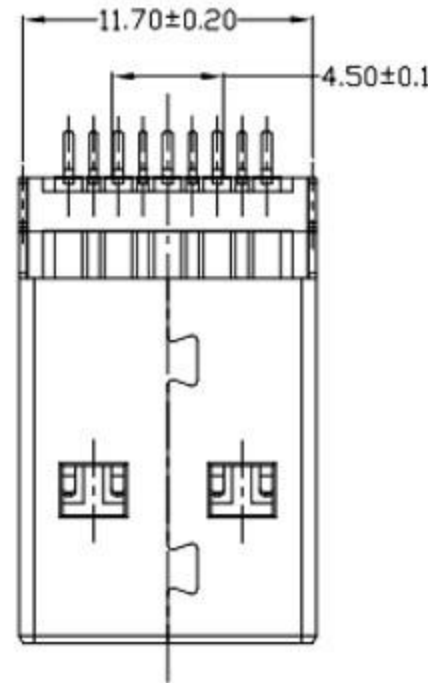
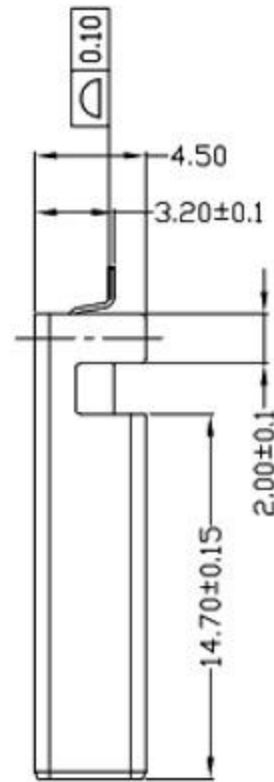
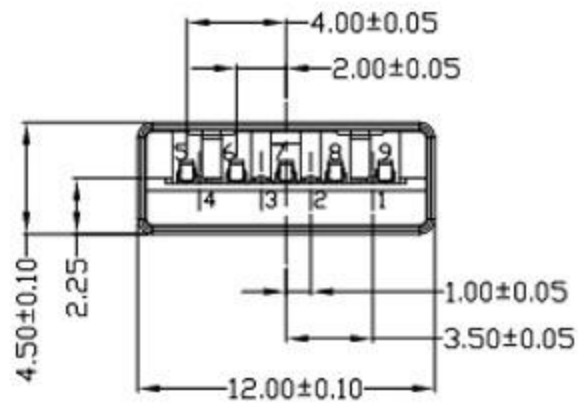
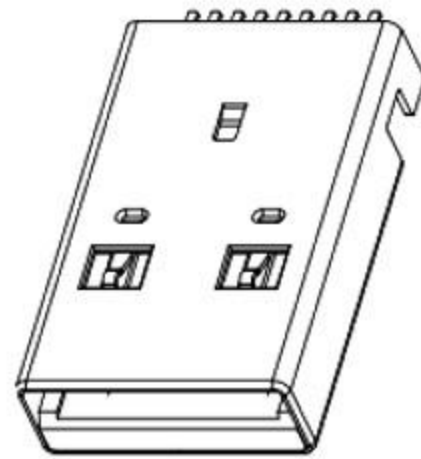
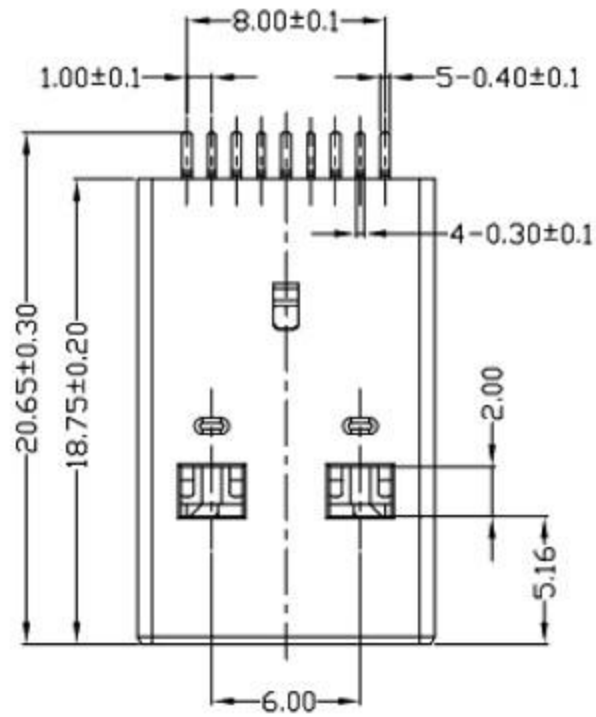

NOTES:

1.ELECTRICAL:

- 1)VOLTAGE CURRENT RATING:1.5AMP,30V AC;
- 2)INSULATION RESISTANCE: 100MΩ MIN;
- 3)CONTACT RESISTANCE: 30mΩ MAX;
- 4)WITHSTANDING VOLTAGE: 500V AC;
- 5)OPERATING TEMPERATURE:-55°C TO +85°C.

2.Mechanical:

- 1)Mating Force: 35N MAX
- 2)Unmating Force: 10N MIN.

3.DIMENSIONS MARKED '▼'

TO BE CHECKED BY Q.C & IPQC.

4. PART NO.

1-Au 1U\*  
5-Au 15U\*  
6-Au 30U\*

W:WHITE  
B:BLACK  
BL:BLUE  
1-PBT  
2-PA6T  
3-PA9T  
4-LCP

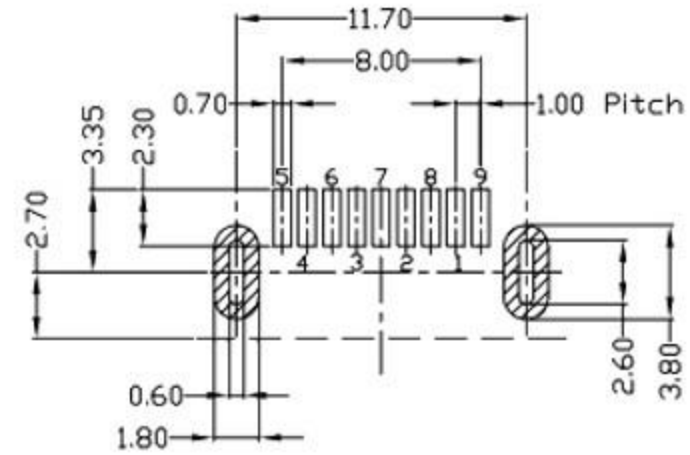

RECOMMENDED P.C.B LAYOUT

⑤	MID PLATE	1	STAINLESS STEEL	Au . PLATING.	T=0.15mm
④	SHELL	1	STAINLESS STEEL	Au . PLATING.	T=0.30mm
③	TERMINAL-B	1	TABLE 2:	TABLE 2:	T=0.12mm
②	TERMINAL-A	1			T=0.12mm
①	INSULATOR	1	HIGH TEMP	Black	
NO.	PART NAME	QTY	MATERIAL	DESCRIPTION	REMARK

UNLESS OTHERWISE,  
GENERAL TOLERANCE:  
X.xxx ±0.10  
X.xx ±0.20  
X.x ±0.30  
X. ±0.38  
ANGULAR:  
X.xx ±1°  
X.x ±3°  
X. ±5°

廣東科斯達電子科技有限公司

TITLE: USB connector  
P/N: Detail See PART NO. LIST  
MODEL:  
DRAW NO.:  
THIRD ANGLE PROJECTION  
UNIT: mm  
SCALE: 1:1  
SIZE: A4  
SHEET: 1/1

JH2016-080	X2	隨工程图上升版本次	2016.06.15	陈少兵	DESIGN	陈少兵	2016.06.15
JH2016-071	X1	新增规格	2016.06.10	陈少兵	CHECK	郑小伟	2016.06.15
20151224001	X	NEW DRAWING	2016.05.05	陈少兵	APPROVAL	吕海涛	2016.06.15
ECN NO.	REV.	DESCRIPTION	DATE	CHANGE	APPROVAL		