

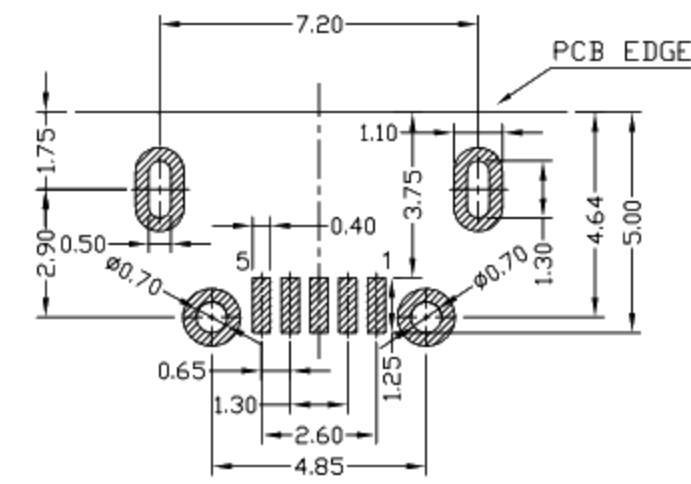

RoHS
Compliant
2002/95/EC

Halogen Free

REV.	ECN.	NO.	APPD.

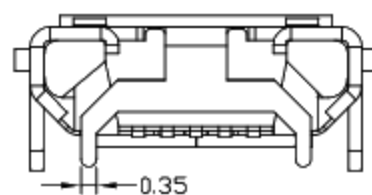
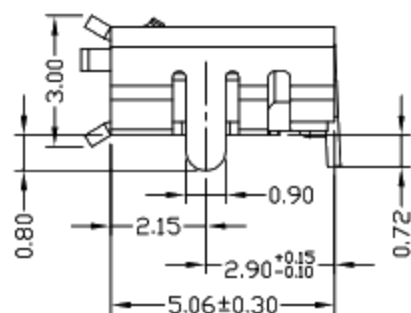
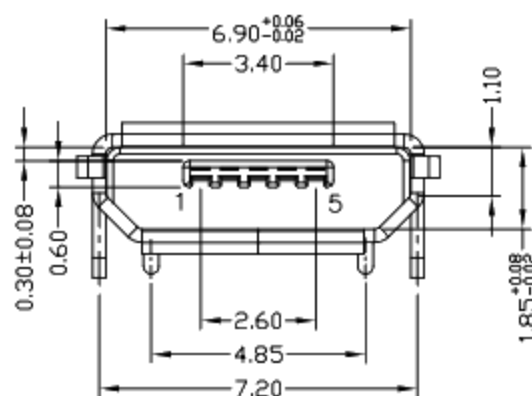
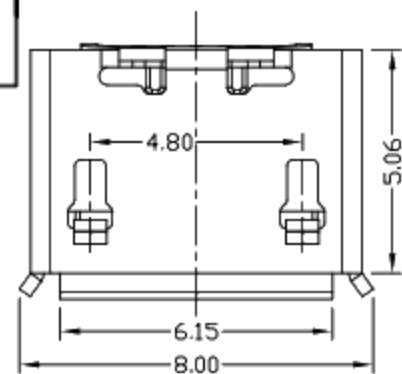

RECOMMENDED PCB LAYOUT

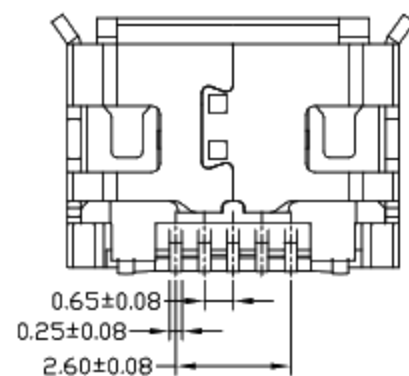

NOTES:

1.ELECTRICAL:

- 1)VOLTAGE CURRENT RATING:PIN1&5 1.8AMP MAX / PIN2&3&4 1AMP MAX. ,30V AC;
- 2)INSULATION RESISTANCE: 100MΩ MIN;
- 3)CONTACT RESISTANCE: 30mΩ MAX;
- 4)WITHSTANDING VOLTAGE: 100V AC; FOR 1 MIN.
- 5)OPERATING TEMPERATURE:-30°C TO +80°C.

2.Mechanical:

- 1)Mating Force: 35N MAX
- 2)Unmating Force: 10N MIN.

3.DIMENSIONS MARKED "▼" TO BE CHECKED BY Q.C & IPQC.

4.PART NO.

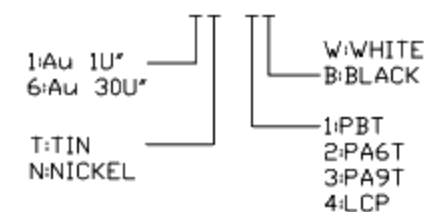

Bill of materials:

NO	PARTS	MATERIAL	QTY	FINISHING	X. ±0.35	X.* ±2'	UNITS	廣東科斯達電子科技有限公司			
3	SHELL	STAINLESS STEEL / COPPER ALLOY	1	PLATED TIN	.X ±0.30	.X* ±1'	mm	TITLE: MICRO USB B TYPE F 5P 四脚全插牛角短针斜后盖0.8版		PART NO.:	
2	HOUSING	LCP+30%GF	1	UL94V-0	.XX ±0.25	.XX*	SEE NOTE	DR: Ricky 2018/4/30		DWG NO.:	
1	TERMINAL	COPPER ALLOY	5	PLATED GOLD	.XXX ±0.15	.XXX*	SEE NOTE	CHKD: Ricky 2018/4/30		SCALE SHEET REV. CUSTOMER DRAWING	
THESE DRAWINGS AND SPECIFICATIONS ARE THE PROPERTY OF ACCURATE INNOTECH INC AND SHALL NOT BE REPRODUCED, COPIED OR USED IN ANY MANNER WITHOUT THE PRIOR WRITTEN CONSENT OF ACCURATE INNOTECH INC								APPD:		5:1 1/1 A	