

RoHS Compliant

NOTES:

1. ELECTRICAL:
  - 1) VOLTAGE CURRENT RATING: 1.5AMP, 30V AC;
  - 2) INSULATION RESISTANCE: 1000MΩ MIN;
  - 3) CONTACT RESISTANCE: 30mΩ MAX;
  - 4) WITHSTANDING VOLTAGE: 500V AC;
  - 5) OPERATING TEMPERATURE: -25°C TO +85°C.
2. Mechanical:
  - 1) Mating Force: 35N MAX
  - 2) Unmating Force: 10N MIN.
3. NOTE: 1. DIMENSIONS MARKED "▼" TO BE CHECKED BY Q.C & IPQC.

1: Au 1U\*  
 5: Au 15u\*  
 6: Au 30U\*

W: WHITE  
 B: BLACK  
 BL: BLUE

1: PBT  
 2: PA6T  
 3: PA9T  
 4: LCP

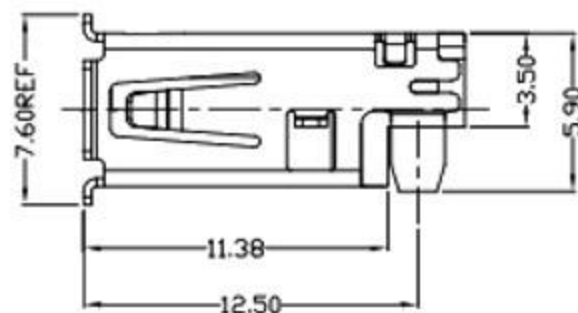
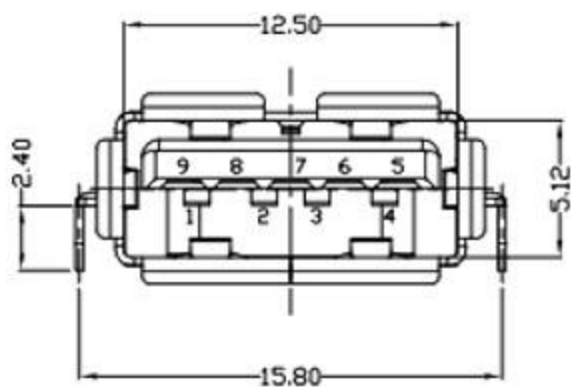
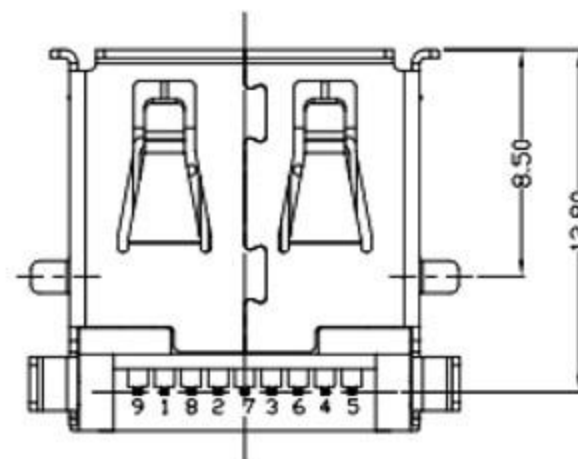
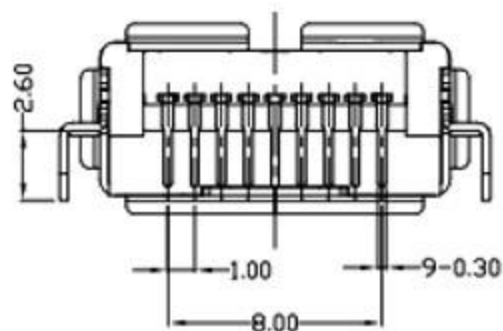
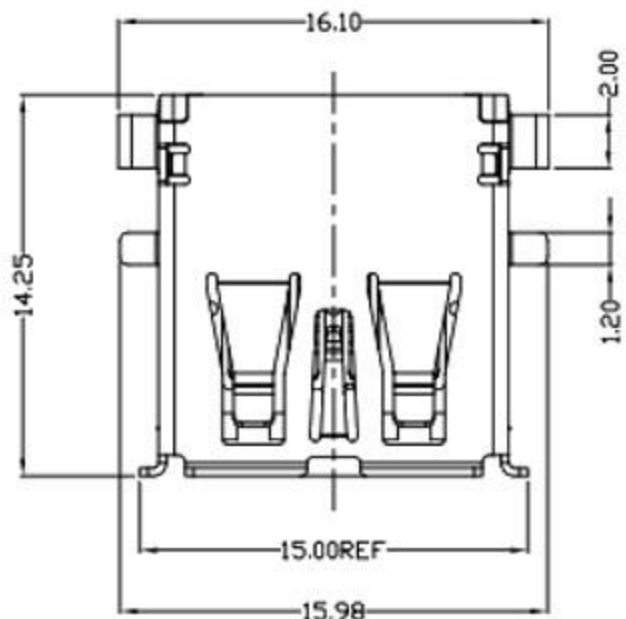

NO.	PART NAME	QTY	MATERIAL	DESCRIPTION	REMARK
⑤	MID PLATE	1	STAINLESS STEEL	Au . PLATING.	T=0.15mm
④	SHELL	1	STAINLESS STEEL	Au . PLATING.	T=0.30mm
③	TERMINAL-B	1	TABLE 2:	TABLE 2:	T=0.12mm
②	TERMINAL-A	1			T=0.12mm
①	INSULATOR	1	HIGH TEMP	Black	

UNLESS OTHERWISE,  
 GENERAL TOLERANCE:  
 X.xxx ±0.10  
 X.xx ±0.20  
 X.x ±0.30  
 X. ±0.38

ANGULAR:  
 X.xx ±1°  
 X.x ±3°  
 X. ±5°

廣東科斯達電子科技有限公司

TITLE: USB connector  
 P/N: Detail See PART NO. LIST  
 MODEL:  
 DRAW NO.:

THIRD ANGLE PROJECTION  
 UNIT: mm  
 SCALE: 1:1  
 SIZE: A4  
 SHEET: 1/1

ECN NO.	REV.	DESCRIPTION	DATE	CHANGE	APPROVAL	吕海涛	2016.06.15
JH2016-080	X2	随工程图上升版本次	2016.06.15	陈少兵	DESIGN	陈少兵	2016.06.15
JH2016-071	X1	新增规格	2016.06.10	陈少兵	CHECK	郑小伟	2016.06.15
20151224001	X	NEW DRAWING	2016.05.05	陈少兵	APPROVAL	吕海涛	2016.06.15