

RoHS Compliant

NOTES:

1. ELECTRICAL:
 - 1) VOLTAGE CURRENT RATING: 1.5AMP, 250V AC;
 - 2) INSULATION RESISTANCE: 1000MΩ MIN;
 - 3) CONTACT RESISTANCE: 30mΩ MAX;
 - 4) WITHSTANDING VOLTAGE: 500V AC;
 - 5) OPERATING TEMPERATURE: -20°C TO +85°C.
2. Mechanical:
 - 1) Mating Force: 35N MAX
 - 2) Unmating Force: 10N MIN.
3. DIMENSIONS MARKED '▼' TO BE CHECKED BY Q.C & IPQC.
4. PART NO.

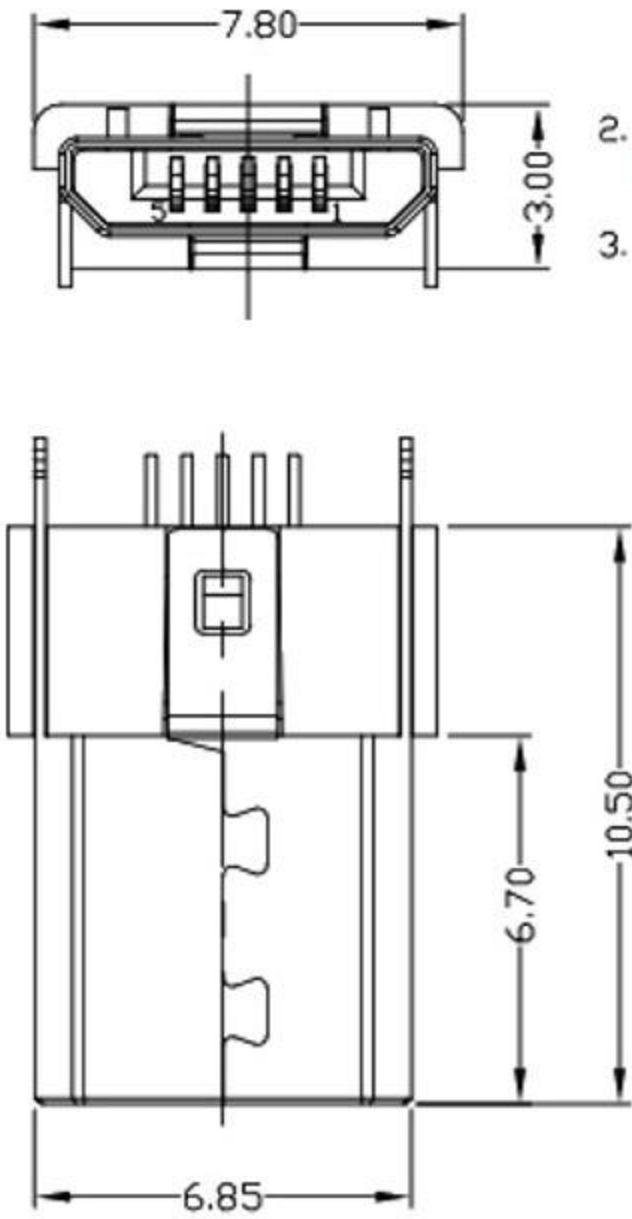
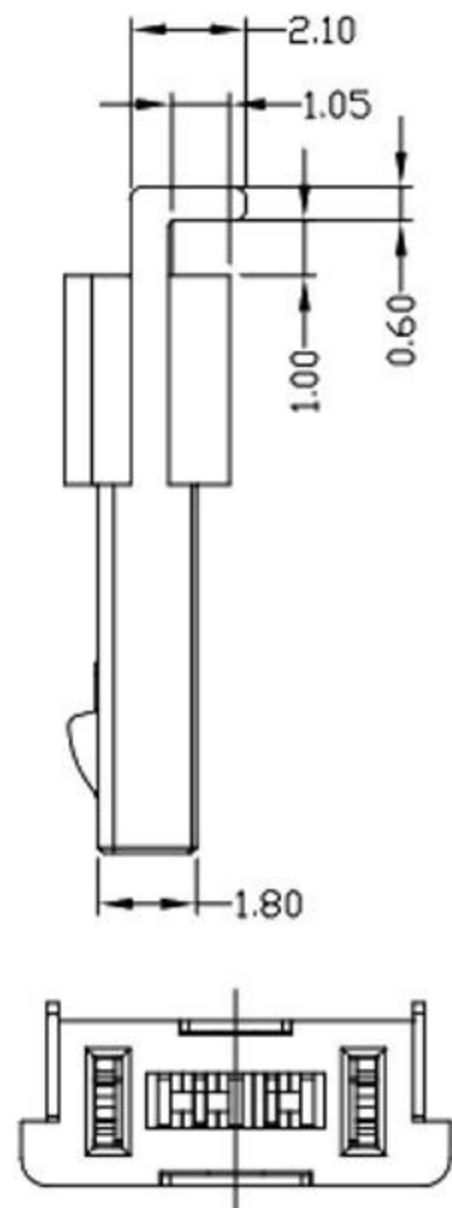
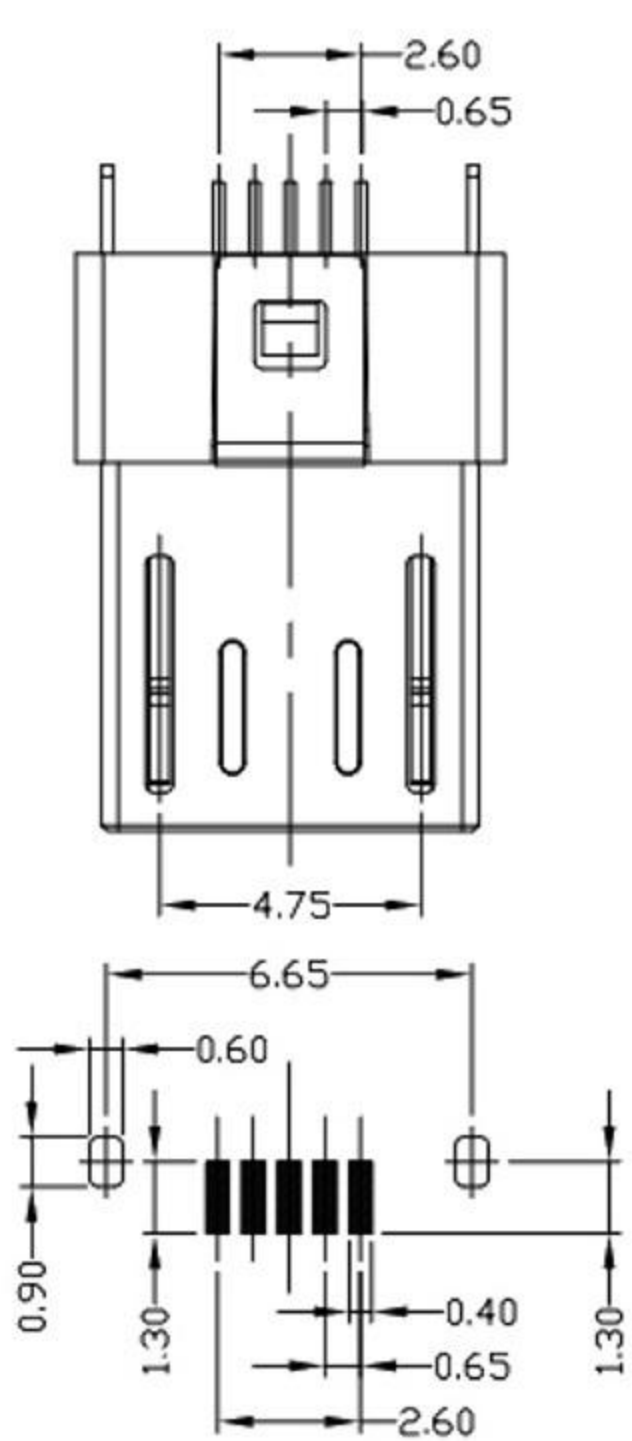

1Au 1U*
6Au 30U*

W/WHITE
B/BLACK

1PBT
2PA6T
3PA9T
4LCP

RECOMMENDED PCB LAYOUT

NO.	PART NAME	QTY	MATERIAL	DESCRIPTION	REMARK
⑤	MID PLATE	1	STAINLESS STEEL	Au . PLATING.	T=0.15mm
④	SHELL	1	STAINLESS STEEL	Au . PLATING.	T=0.30mm
③	TERMINAL-B	1	TABLE 2:	TABLE 2:	T=0.12mm
②	TERMINAL-A	1			T=0.12mm
①	INSULATOR	1	HIGH TEMP	Black	

UNLESS OTHERWISE,
GENERAL TOLERANCE:

X.xxx ±0.10
X.xx ±0.20
X.x ±0.30
X. ±0.38

ANGULAR:

X.xx ±1°
X.x ±3°
X. ±5°

廣東科斯達電子科技有限公司

TITLE: USB connector		P/N: Detail See PART NO. LIST		
THIRD ANGLE PROJECTION		DRAW NO.:		
UNIT: mm	SCALE: 1:1	SIZE: A4	SHEET: 1/1	

ECN NO.	REV.	DESCRIPTION	DATE	CHANGE	APPROVAL	DATE
JH2016-080	X2	隨工程图上升版本次	2016.06.15	陈少兵	DESIGN	2016.06.15
JH2016-071	X1	新增规格	2016.06.10	陈少兵	CHECK	2016.06.15
20151224001	X	NEW DRAWING	2016.05.05	陈少兵	APPROVAL	2016.06.15