

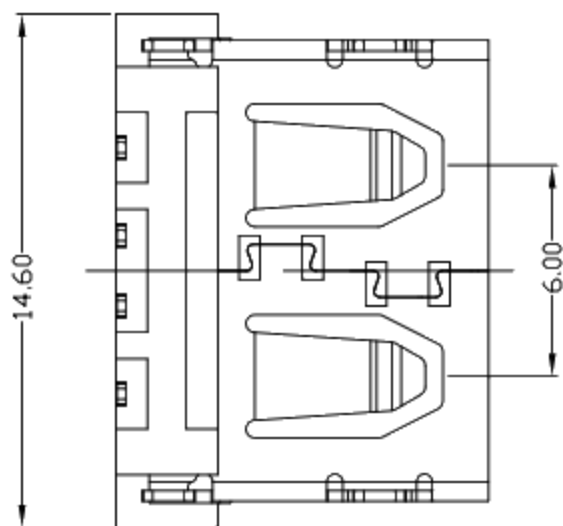

RoHS
Compliant
2002/95/EC

REV.	ECN.	NO.	APPD.

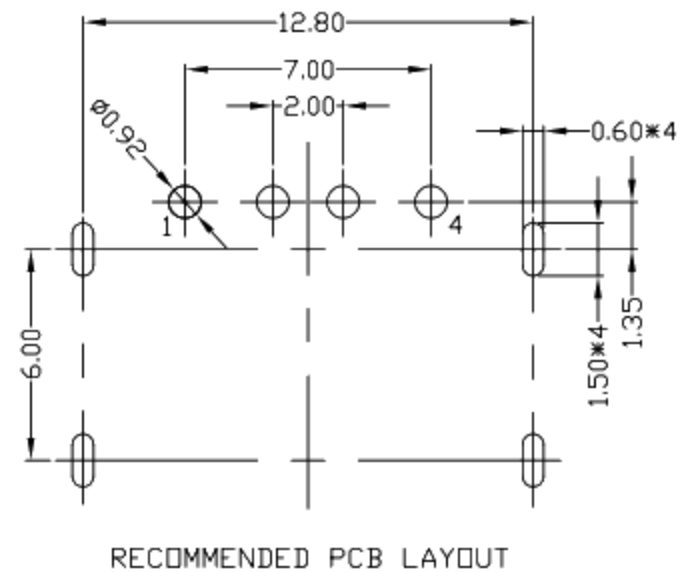
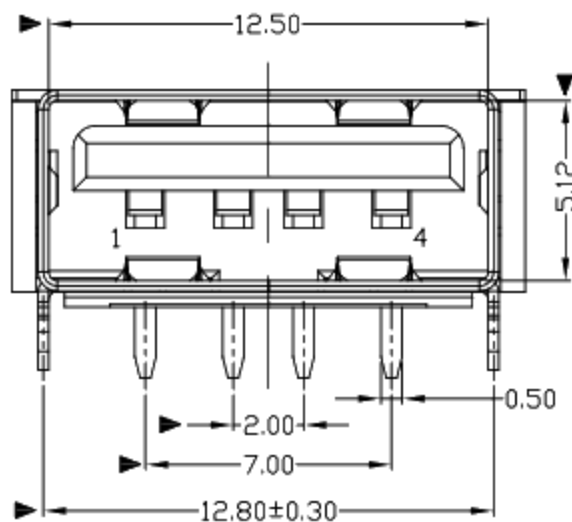
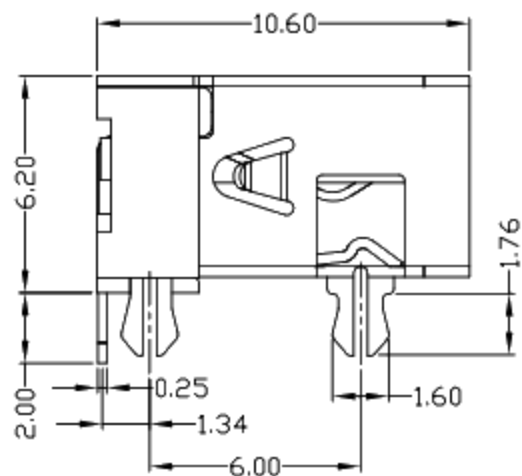

NOTES:

- ELECTRICAL:
 - VOLTAGE CURRENT RATING: 2AMP, 30V AC;
 - INSULATION RESISTANCE: 1000MΩ MIN;
 - CONTACT RESISTANCE: 30mΩ MAX;
 - WITHSTANDING VOLTAGE: 500V AC;
 - OPERATING TEMPERATURE: -55°C TO +85°C.
- Mechanical:
 - Mating Force: 35N MAX
 - Unmating Force: 10N MIN.
- NOTE: 1. DIMENSIONS MARKED "▼" TO BE CHECKED BY Q.C & IPQC.

4.PART NO.

1: Au 1U*
6: Au 30U*

W: WHITE
B: BLACK

1: PBT
2: PA6T
3: PA9T
4: LCP

Bill of materials:

NO	PARTS	MATERIAL	QTY	FINISHING	UNITS	mm	廣東科斯達電子科技有限公司						
3	HOUSING	PBT/LCP	1	UL94V-0	X. ±0.35	X.* ±2*	SEE NOTE	TITLE:		PART NO.:			
2	SHELL	COPPER ALLOY	1	PLATED NICKEL	.X ±0.3	.X* ±1*		USB A/F 90度 短休叉叉脚4脚(10.6)		DWG NO.:			
1	TERMINAL	COPPER ALLOY	4	PLATED GOLD/TIN	.XX ±0.25	.XX*		DR: gan 2012/7/04		SCALE SHEET REV. CUSTOMER DRAWING			
					.XXX ±0.15	.XXX*	SEE NOTE	CHKD: gan 2012/7/04		1:1	1/1	B	
							Q'TY	APPD:					

THESE DRAWINGS AND SPECIFICATIONS ARE THE PROPERTY OF ACCURATE INNOTECH INC AND SHALL NOT BE REPRODUCED, COPIED OR USED IN ANY MANNER WITHOUT THE PRIOR WRITTEN CONSENT OF ACCURATE INNOTECH INC.

