

RoHS Compliant

NOTES:

1.ELECTRICAL:

- 1)CURRENT RATING: 3AMP MAX;
- 2)INSULATION RESISTANCE: 100MΩ MIN;  
MEASURED BY 500 VDC.
- 3)CONTACT RESISTANCE: 30mΩ MAX;
- 4)WITHSTANDING VOLTAGE: 100V AC; FOR 1 MIN.
- 5)OPERATING TEMPERATURE:-30°C TO +85°C.

2.Mechanical:

- 1)Mating Force: 5N~20N
- 2)Unmating Force: 8N~20N
- 3)Durability: 10,000 cycles

3.DIMENSIONS MARKED "▼"  
TO BE CHECKED BY Q.C & IPQC.

4.PART NO.

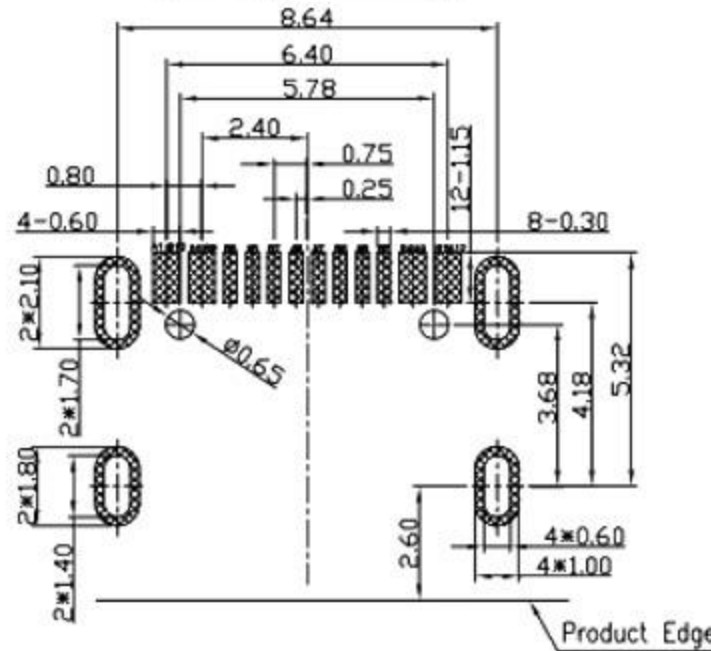
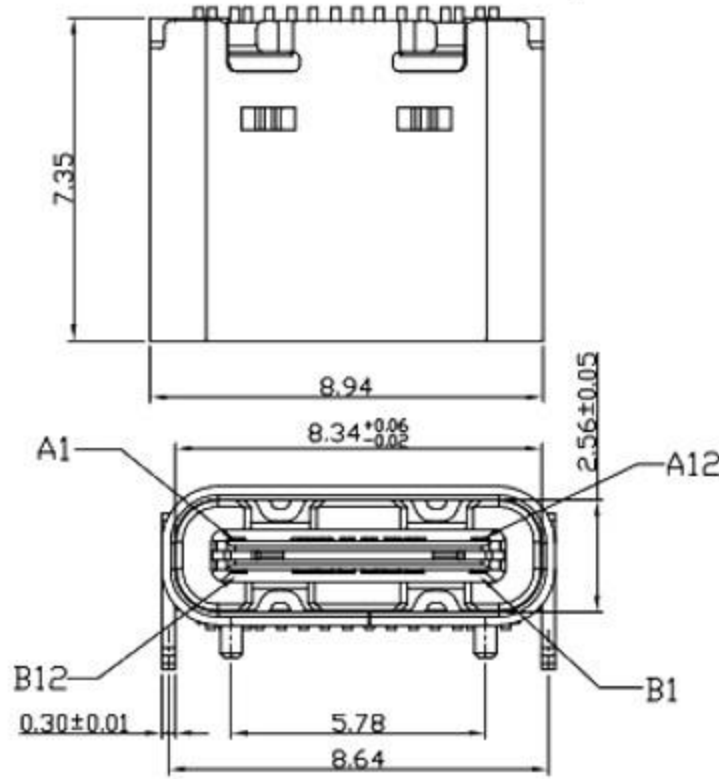
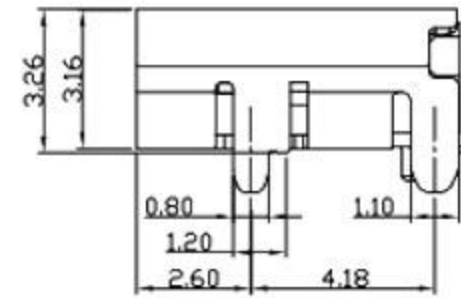
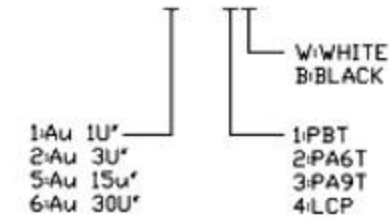
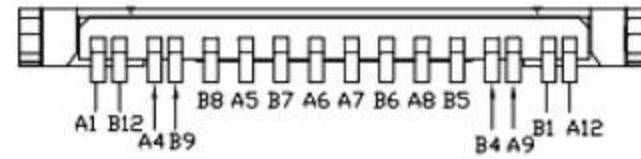
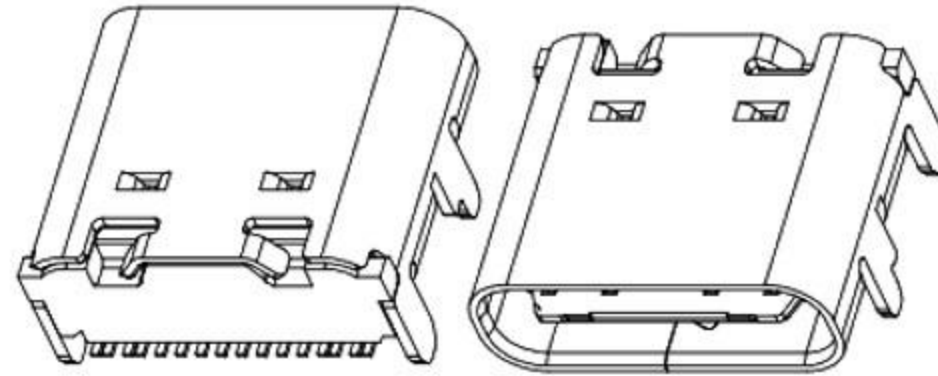
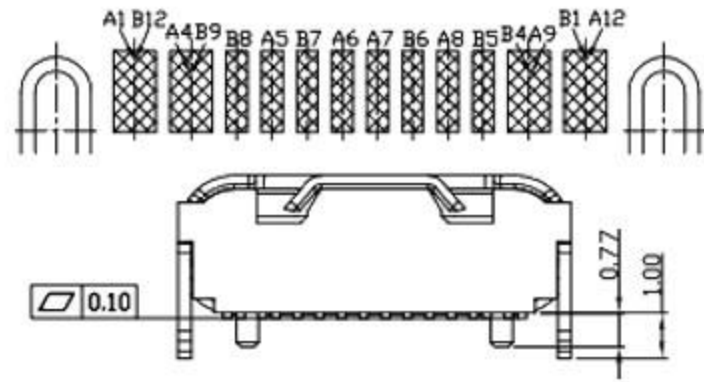

|     |             |     |             |
|-----|-------------|-----|-------------|
| A1  | GND         | B12 | GND         |
| A4  | VBUS        | B9  | VBUS        |
| A5  | CC1         | B8  | SBU2        |
| A6  | DP1         | B7  | DN2         |
| A7  | DN1         | B6  | DP2         |
| A8  | SBU1        | B5  | CC2         |
| A9  | VBUS        | B4  | VBUS        |
| A12 | GND         | B1  | GND         |
| PIN | SIGNAL NAME | PIN | SIGNAL NAME |

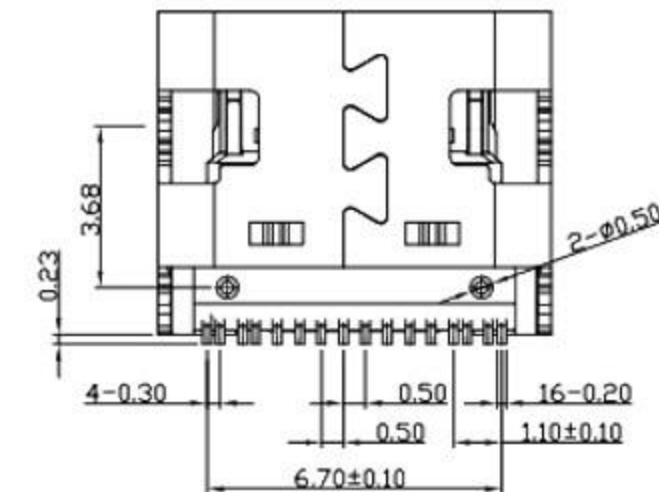

RECOMMENDED P.C.B. LAYOUT(T:1.00mm)  
TOLERANCE UNSPECIFIED ±0.05mm

|     |            |     |                 |               |          |
|-----|------------|-----|-----------------|---------------|----------|
| ⑤   | MID PLATE  | 1   | STAINLESS STEEL | Au . PLATING. | T=0.15mm |
| ④   | SHELL      | 1   | STAINLESS STEEL | Au . PLATING. | T=0.30mm |
| ③   | TERMINAL-B | 1   | TABLE 2:        | TABLE 2:      | T=0.12mm |
| ②   | TERMINAL-A | 1   |                 |               | T=0.12mm |
| ①   | INSULATOR  | 1   | HIGH TEMP       | Black         |          |
| NO. | PART NAME  | QTY | MATERIAL        | DESCRIPTION   | REMARK   |

UNLESS OTHERWISE,  
GENERAL TOLERANCE:  
X.xxx ±0.10  
X.xx ±0.20  
X.x ±0.30  
X. ±0.38  
ANGULAR:  
X.xx ±1°  
X.x ±3°  
X. ±5°

廣東科斯達電子科技有限公司

|                         |                               |
|-------------------------|-------------------------------|
| TITLE:<br>USB connector | P/N: Detail See PART NO. LIST |
| MODEL:                  | DRAW NO.:                     |
| THIRD ANGLE PROJECTION  | UNIT: mm                      |
| SCALE: 1:1              | SIZE: A4                      |
| SHEET: 1/1              |                               |

|             |      |             |            |        |          |     |            |
|-------------|------|-------------|------------|--------|----------|-----|------------|
| JH2016-080  | X2   | 隨工程圖上升版本次   | 2016.06.15 | 陳少兵    | DESIGN   | 陳少兵 | 2016.06.15 |
| JH2016-071  | X1   | 新增規格        | 2016.06.10 | 陳少兵    | CHECK    | 鄭小偉 | 2016.06.15 |
| 20151224001 | X    | NEW DRAWING | 2016.05.05 | 陳少兵    | APPROVAL | 呂海濤 | 2016.06.15 |
| ECN NO.     | REV. | DESCRIPTION | DATE       | CHANGE |          |     |            |