

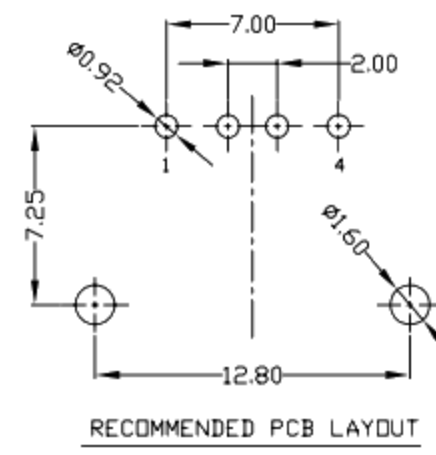

RoHS
Compliant
2002/95/EC

REV	LTR	DESCRIPTION	DATE	REVISER	APPD

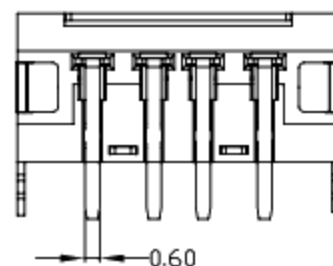
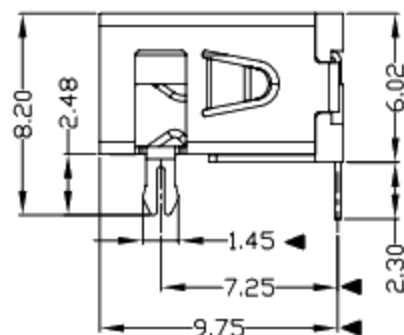
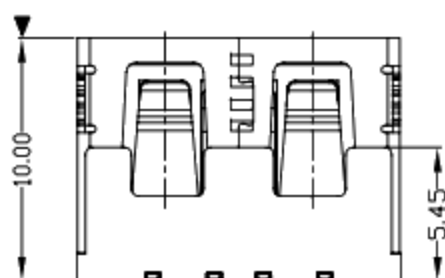
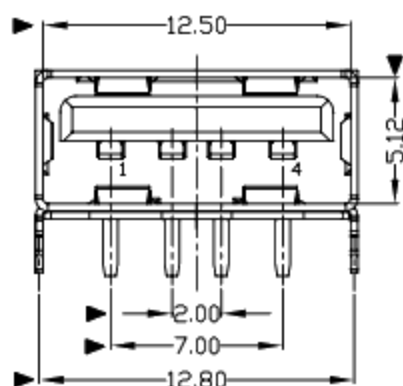
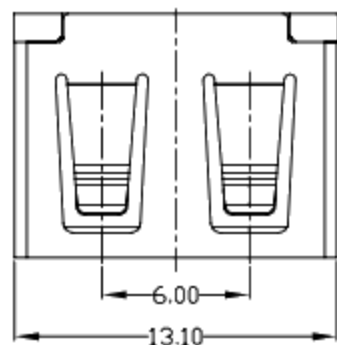

NOTES:

1. ELECTRICAL:

- 1) VOLTAGE CURRENT RATING: 2AMP, 30V AC;
- 2) INSULATION RESISTANCE: 1000M Ω , MIN;
- 3) CONTACT RESISTANCE: 30m Ω MAX;
- 4) WITHSTANDING VOLTAGE: 500V AC;
- 5) OPERATING TEMPERATURE: -55°C TO +85°C.

2. Mechanical:

- 1) Mating Force: 35N MAX
- 2) Unmating Force: 10N MIN.

3. NOTE: 1. DIMENSIONS MARKED "▼" TO BE CHECKED BY Q.C & IPQC.

4. PART NO.

1: Au 1U*
6: Au 30U*

W: WHITE
B: BLACK
1: PBT
2: PA6T
3: PA9T
4: LCP

Bill of materials:

NO	PARTS	MATERIAL	QTY	FINISHING	UNITS	mm	廣東科斯達電子科技有限公司					
3	HOUSING	PBT+30%GF	1	UL94V-0	X. ± 0.35	X.* $\pm 2^*$	TITLE:	PART NO.:				
2	SHELL	COPPER ALLOY	1	PLATED NICKEL	.X ± 0.30	.X* $\pm 1^*$	DR:	DWG NO.:				
1	TERMINAL	COPPER ALLOY	4	PLATED GOLD/TIN	.XXX ± 0.15	.XXX*	CHKD:	SCALE SHEET REV. CUSTOMER DRAWING				
THESE DRAWINGS AND SPECIFICATIONS ARE THE PROPERTY OF ACCURATE INNOTECH INC AND SHALL NOT BE REPRODUCED, COPIED OR USED IN ANY MANNER WITHOUT THE PRIOR WRITTEN CONSENT OF ACCURATE INNOTECH INC.							Q'TY	APPD:	1:1	1/1	B	

