

RoHS Compliant

NOTES:

- ELECTRICAL:
 - CURRENT RATING: 3AMP MAX;
 - INSULATION RESISTANCE: 100MΩ MIN;
 - CONTACT RESISTANCE: 40mΩ MAX;
 - WITHSTANDING VOLTAGE: 100V AC;
 - OPERATING TEMPERATURE: -30°C TO +85°C.
- Mechanical:
 - Mating Force: 5N~20N
 - Unmating Force: 8N~20N
 - Durability: 10,000 cycles
- DIMENSIONS MARKED "▽" TO BE CHECKED BY Q.C & IPQC.
- PART NO.

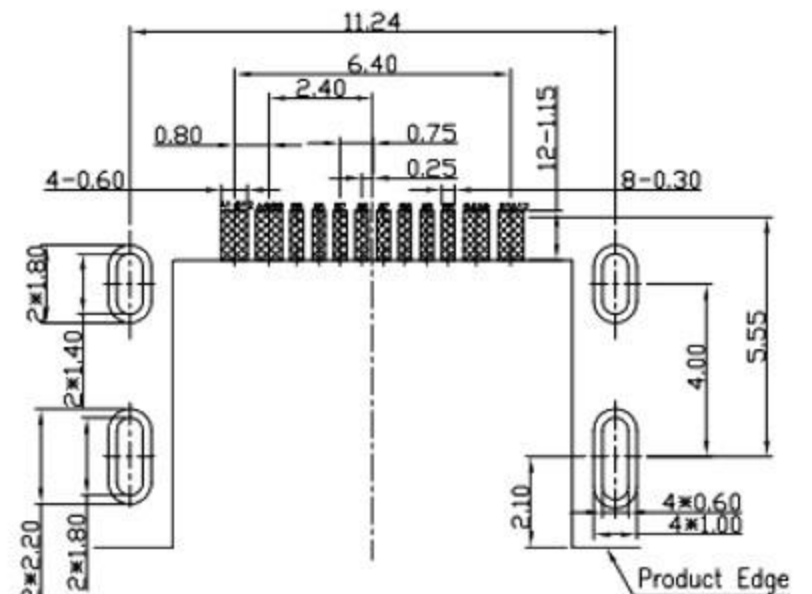
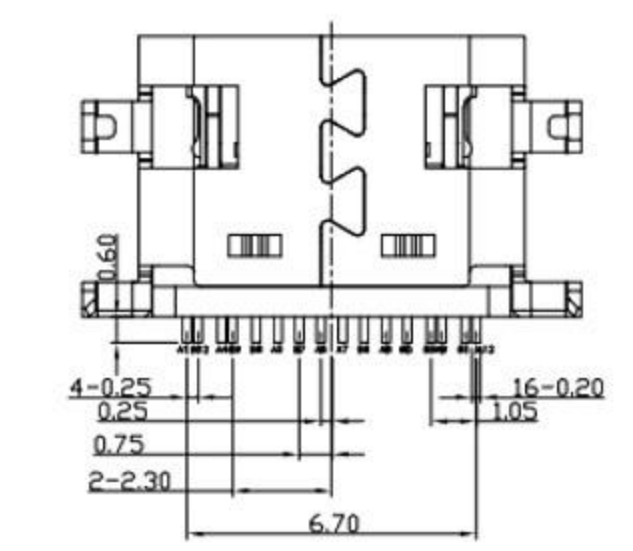
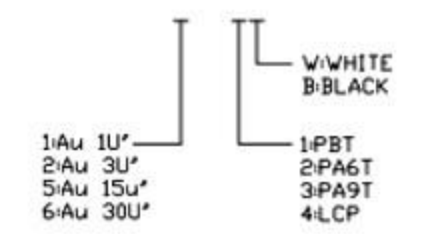
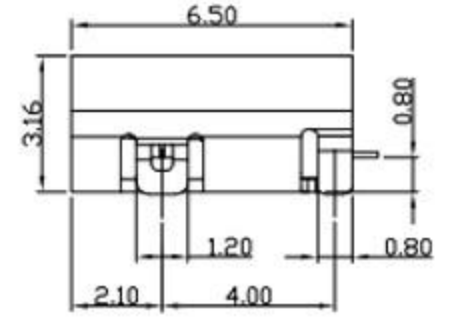
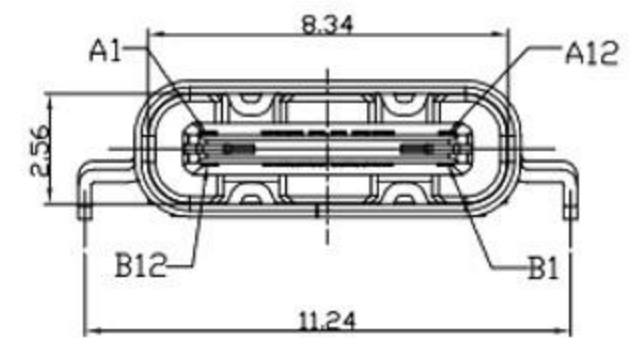
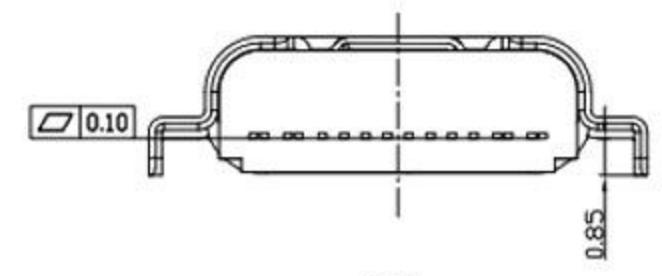
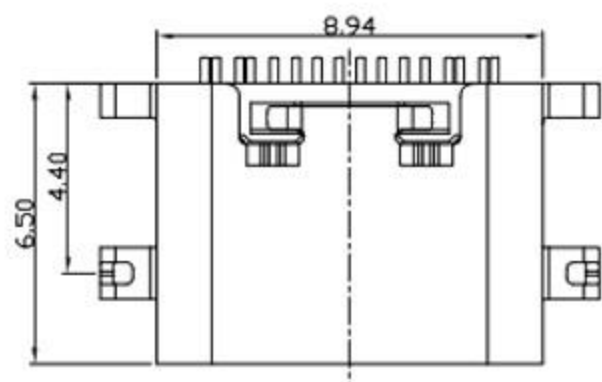

PIN	SIGNAL NAME	PIN	SIGNAL NAME
A1	GND	B12	GND
A4	VBUS	B9	VBUS
A5	CC1	B8	SBU2
A6	DP1	B7	DN2
A7	DN1	B6	DP2
A8	SBU1	B5	CC2
A9	VBUS	B4	VBUS
A12	GND	B1	GND

NO.	PART NAME	QTY	MATERIAL	DESCRIPTION	REMARK
⑤	MID PLATE	1	STAINLESS STEEL	Au . PLATING.	T=0.15mm
④	SHELL	1	STAINLESS STEEL	Au . PLATING.	T=0.30mm
③	TERMINAL-B	1	TABLE 2:	TABLE 2:	T=0.12mm
②	TERMINAL-A	1	TABLE 2:	TABLE 2:	T=0.12mm
①	INSULATOR	1	HIGH TEMP	Black	

RECOMMENDED P.C.B. LAYOUT
TOLERANCE UNSPECIFIED ±0.05mm

UNLESS OTHERWISE, GENERAL TOLERANCE:
 X.xxx ±0.10
 X.xx ±0.20
 X.x ±0.30
 X. ±0.38

ANGULAR:
 X.xx ±1°
 X.x ±3°
 X. ±5°

廣東科斯達電子科技有限公司

TITLE: USB connector
 P/N: Detail See PART NO. LIST
 MODEL:
 DRAW NO.:

THIRD ANGLE PROJECTION UNIT: mm SCALE: 1:1 SIZE: A4 SHEET: 1/1

ECN NO.	REV.	DESCRIPTION	DATE	CHANGE	APPROVAL	DATE
JH2016-080	X2	隨工程圖上升版本次	2016.06.15	陳少兵	DESIGN	2016.06.15
JH2016-071	X1	新增規格	2016.06.10	陳少兵	CHECK	2016.06.15
20151224001	X	NEW DRAWING	2016.05.05	陳少兵	APPROVAL	2016.06.15