

RoHS Compliant

NOTES:

1. ELECTRICAL:
 - 1) CURRENT RATING: 3AMP MAX;
 - 2) INSULATION RESISTANCE: 100MΩ MIN 250V DC;
 - 3) CONTACT RESISTANCE: 40mΩ MAX;
 - 4) WITHSTANDING VOLTAGE: 100V AC;
 - 5) OPERATING TEMPERATURE: -30°C TO +85°C.
2. Mechanical:
 - 1) Mating Force: 20N MAX.
 - 2) Unmating Force: 6N MIN.
3. DIMENSIONS MARKED "▼"
TO BE CHECKED BY Q.C & IPQC.

4. PART NO.

1Au 1U'	W-WHITE
2Au 3U'	B-BLACK
5Au 15u'	1PBT
6Au 30U'	2-PA6T
	3-PA9T
	4-LCP

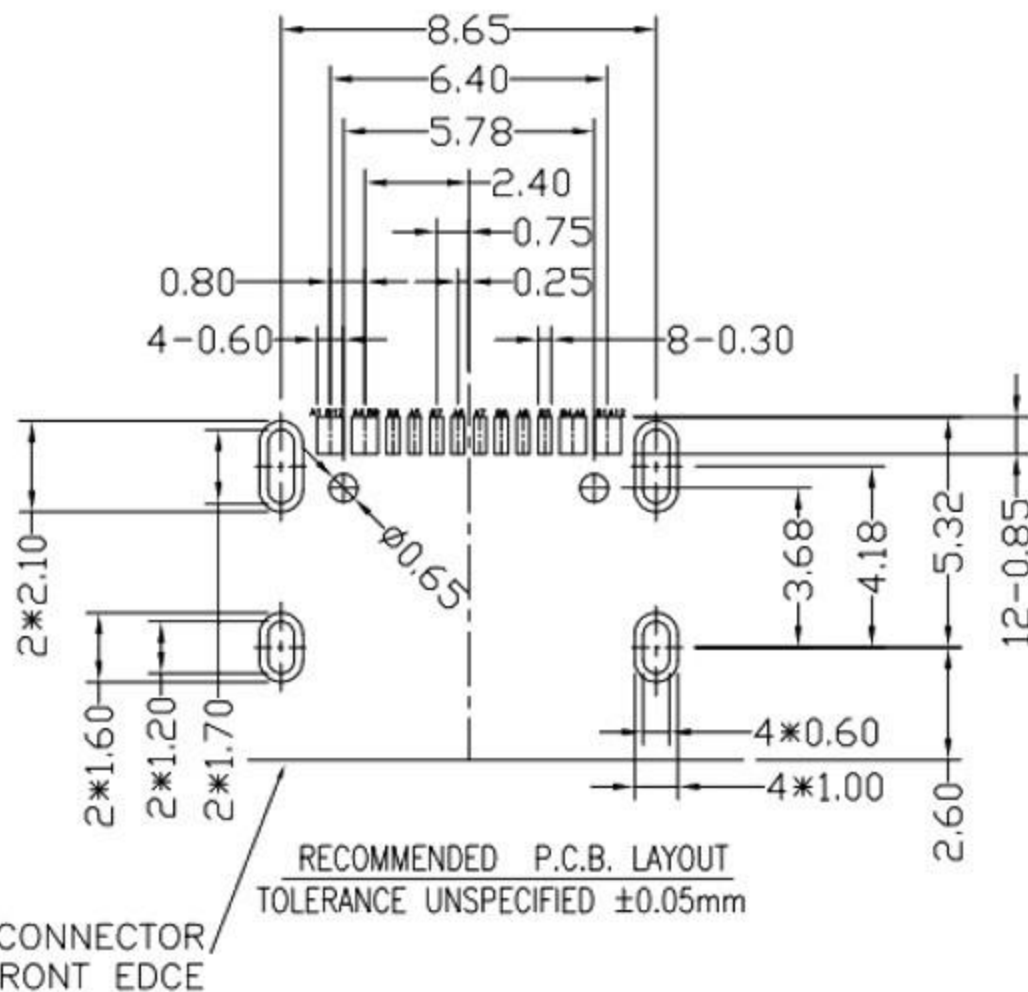
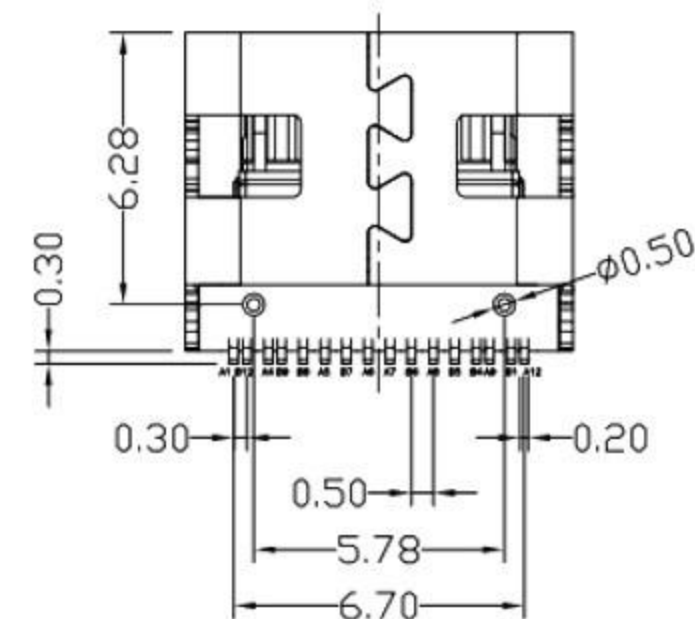
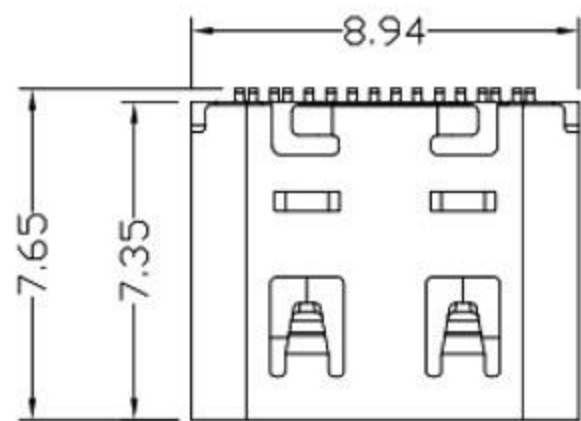
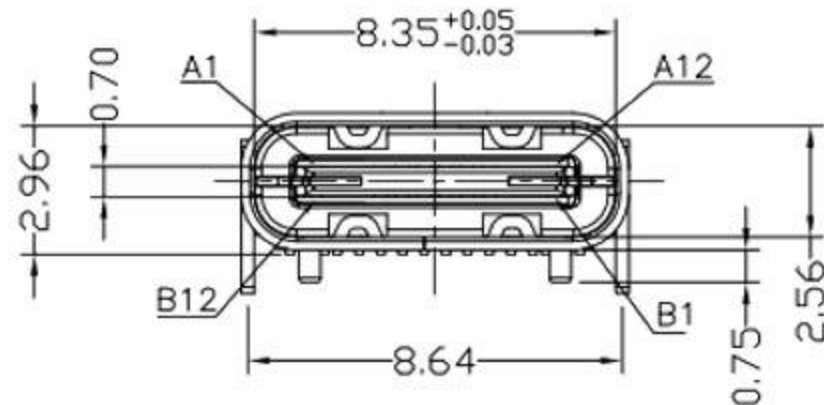
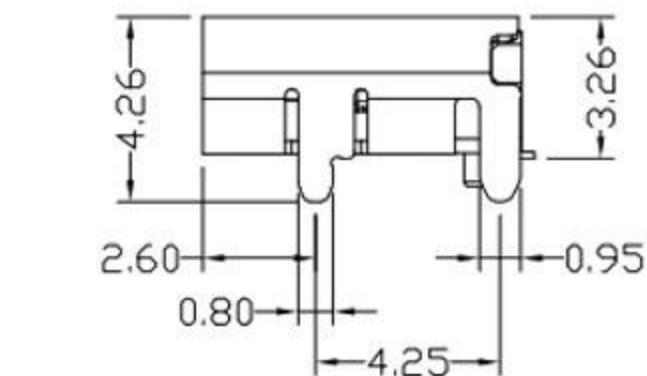

A1	GND	B12	GND
A4	VBUS	B9	VBUS
A5	CC1	B8	SBU2
A6	DP1	B7	DN2
A7	DN1	B6	DP2
A8	SBU1	B5	CC2
A9	VBUS	B4	VBUS
A12	GND	B1	GND
PIN	SIGNAL NAME	PIN	SIGNAL NAME

⑤	MID PLATE	1	STAINLESS STEEL	Au . PLATING.	T=0.15mm
④	SHELL	1	STAINLESS STEEL	Au . PLATING.	T=0.30mm
③	TERMINAL-B	1	TABLE 2:	TABLE 2:	T=0.12mm
②	TERMINAL-A	1	TABLE 2:	TABLE 2:	T=0.12mm
①	INSULATOR	1	HIGH TEMP	Black	
NO.	PART NAME	QTY	MATERIAL	DESCRIPTION	REMARK

UNLESS OTHERWISE,
GENERAL TOLERANCE:
X.xxx ±0.10
X.xx ±0.20
X.x ±0.30
X. ±0.38

ANGULAR:
X.xx ±1°
X.x ±3°
X. ±5°

廣東科斯達電子科技有限公司

TITLE: USB connector	P/N: Detail See PART NO. LIST
MODEL:	DRAW NO.:
THIRD ANGLE PROJECTION	UNIT: mm
SCALE: 1:1	SIZE: A4
SHEET: 1/1	

JH2016-080	X2	隨工程图上升版本次	2016.06.15	陈少兵	DESIGN	陈少兵	2016.06.15
JH2016-071	X1	新增规格	2016.06.10	陈少兵	CHECK	郑小伟	2016.06.15
20151224001	X	NEW DRAWING	2016.05.05	陈少兵	APPROVAL	吕海涛	2016.06.15
ECN NO.	REV.	DESCRIPTION	DATE	CHANGE	APPROVAL		