

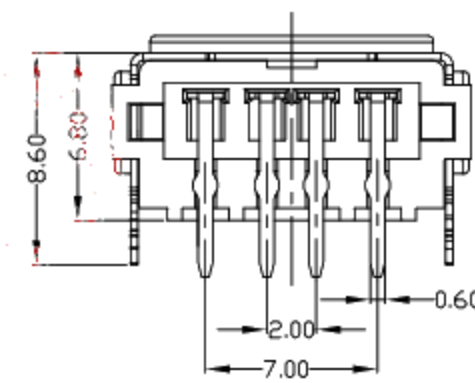

RoHS  
Compliant  
2002/95/EC

REV	LTR	DESCRIPTION	DATE	REVISER	APPD

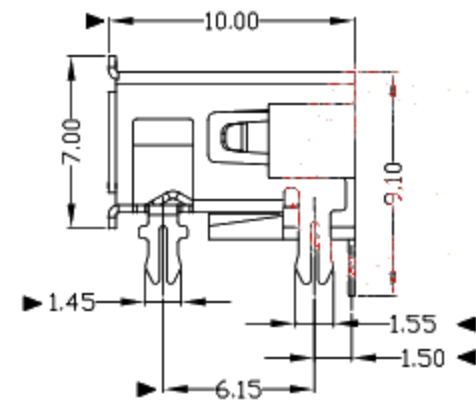
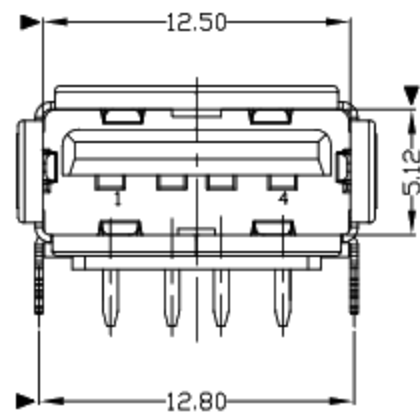
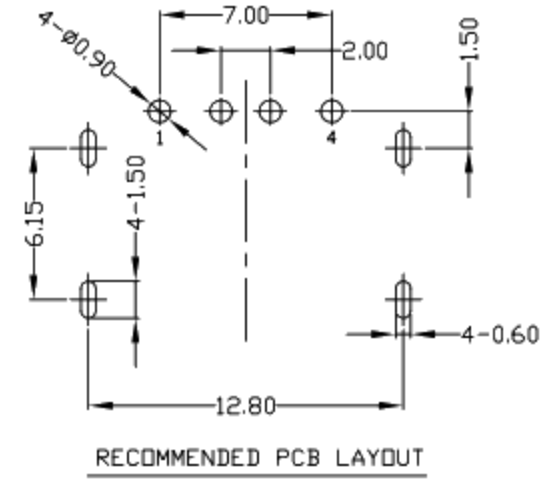
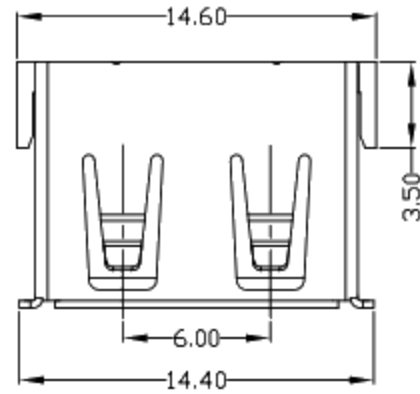

- NOTES:
- ELECTRICAL:
    - VOLTAGE CURRENT RATING: 2AMP, 30V AC;
    - INSULATION RESISTANCE: 1000MΩ, MIN;
    - CONTACT RESISTANCE: 30mΩ MAX;
    - WITHSTANDING VOLTAGE: 500V AC;
    - OPERATING TEMPERATURE: -55°C TO +85°C.
  - Mechanical:
    - Mating Force: 35N MAX
    - Unmating Force: 10N MIN.
  - NOTE: 1. DIMENSIONS MARKED '▼' TO BE CHECKED BY Q.C & IPQC.
  - PART NO.

1Au 10'  
6Au 30U'

W: WHITE  
B: BLACK

1PBT  
2PA6T  
3PA9T  
4LCP

Bill of materials:

NO	PARTS	MATERIAL	QTY	FINISHING			
3	HOUSING	PBT+30%GF	1	UL94V-0	X. ±0.35	X.' ±2'	UNITS mm
2	SHELL	COPPER ALLOY/SPCC	1	PLATED NICKEL	.X ±0.30	.X' ±1'	MAT'L
1	TERMINAL	COPPER ALLOY	4	PLATED GOLD/TIN	.XX ±0.25	.XX'	SEE NOTE
					.XXX ±0.15	.XXX'	FINISH
							SEE NOTE
							Q'TY

THESE DRAWINGS AND SPECIFICATIONS ARE THE PROPERTY OF ACCURATE (INNOTECH) INC AND SHALL NOT BE REPRODUCED, COPIED OR USED IN ANY MANNER WITHOUT THE PRIOR WRITTEN CONSENT OF ACCURATE (INNOTECH) INC.

**廣東科斯達電子科技有限公司**

TITLE: USB AF DIP 90度 10.0四只脚插板

PART NO.:

DR: gan 2013/5/9

DWG NO.:

CHKD: gan 2013/5/9

APPD:

SCALE	SHEET	REV.	CUSTOMER DRAWING
1:1	1/1	B	