

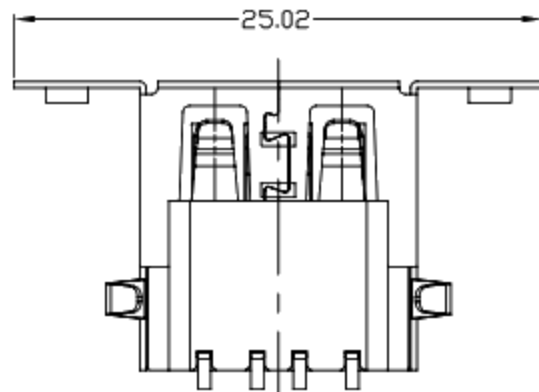

RoHS Compliant
2002/95/EC

REV	LTR	DESCRIPTION	DATE	REVISER	APPD
B	△	尺寸变更	10/12/02	ganqingwen	
C	△	尺寸变更	11/02/19	ganqingwen	

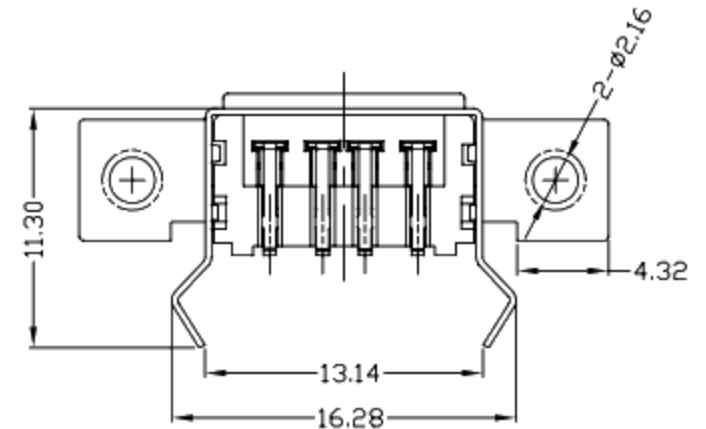
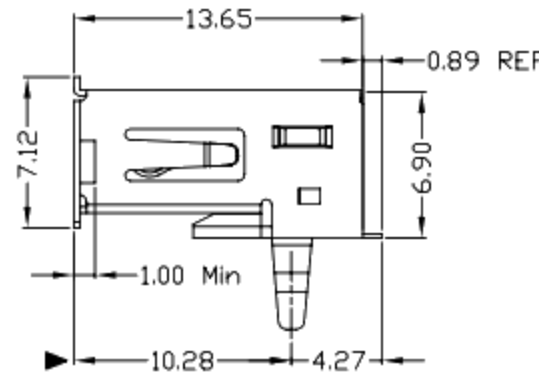
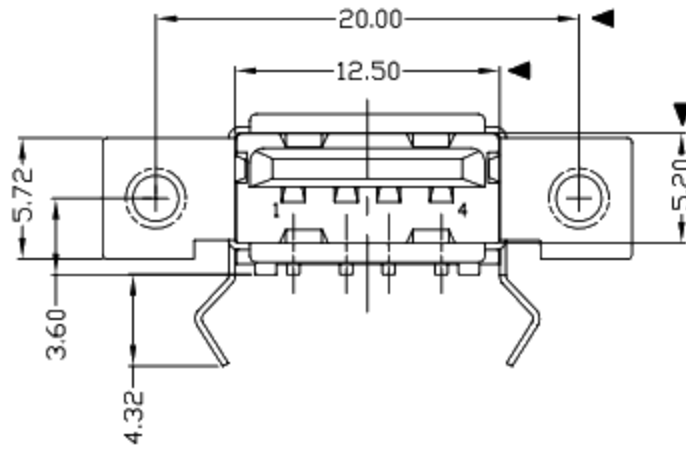
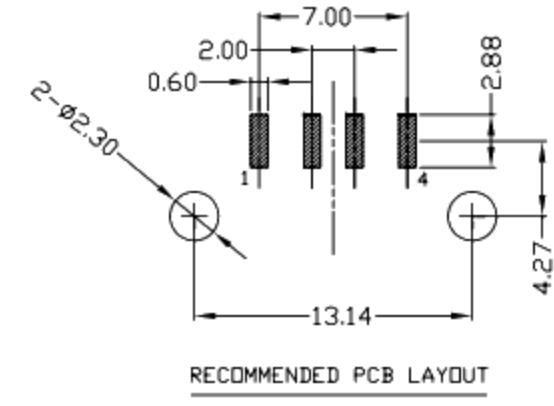
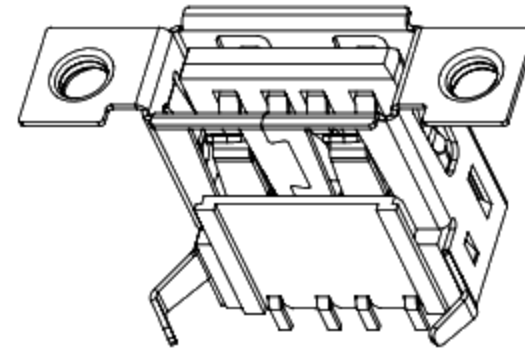
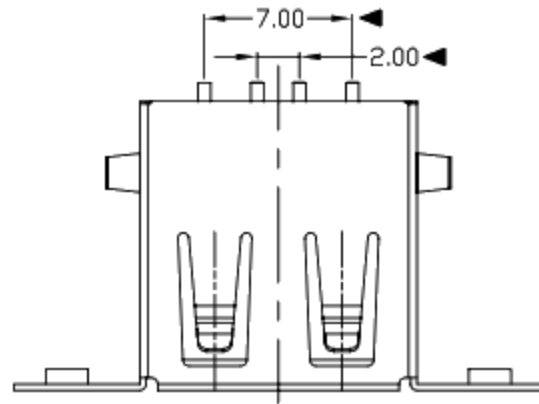

NOTES:

- ELECTRICAL:
 - VOLTAGE CURRENT RATING: 2AMP, 30V AC;
 - INSULATION RESISTANCE: 1000MΩ MIN;
 - CONTACT RESISTANCE: 30mΩ MAX;
 - WITHSTANDING VOLTAGE: 500V AC;
 - OPERATING TEMPERATURE: -55°C TO +85°C.
- Mechanical:
 - Mating Force: 35N MAX
 - Unmating Force: 10N MIN.
- NOTE: 1. DIMENSIONS MARKED "▼" TO BE CHECKED BY Q.C & IPQC.

4.PART NO.

1-Au 1U'
6-Au 30U'

W: WHITE
B: BLACK
1-PBT
2-PA6T
3-PA9T
4-LCP

Bill of materials:

NO	PARTS	MATERIAL	QTY	FINISHING	UNITS	mm	廣東科斯達電子科技有限公司					
3	HOUSING	LCP	1	UL94V-0	X. ±0.35	X.* ±2*	SEE NOTE	TITLE: USB A/F 90° SMT左右帶螺孔		PART NO.:		
2	SHELL	COPPER ALLOY	1	PLATED NICKEL	.X ±0.3	.X* ±1*						
1	TERMINAL	COPPER ALLOY	4	PLATED GOLD/TIN	.XX ±0.25	.XX*						
					.XXX ±0.15	.XXX*						
					THESE DRAWINGS AND SPECIFICATIONS ARE THE PROPERTY OF ACCURATE INNOTECH INC AND SHALL NOT BE REPRODUCED, COPIED OR USED IN ANY MANNER WITHOUT THE PRIOR WRITTEN CONSENT OF ACCURATE INNOTECH INC.		Q'TY	DR: gan 2013/8/9		DWG NO.:		
							APPD:	CHKD: gan 2013/8/9	SCALE	SHEET	REV.	CUSTOMER DRAWING
									1:1	1/1	B	