

RoHS Compliant

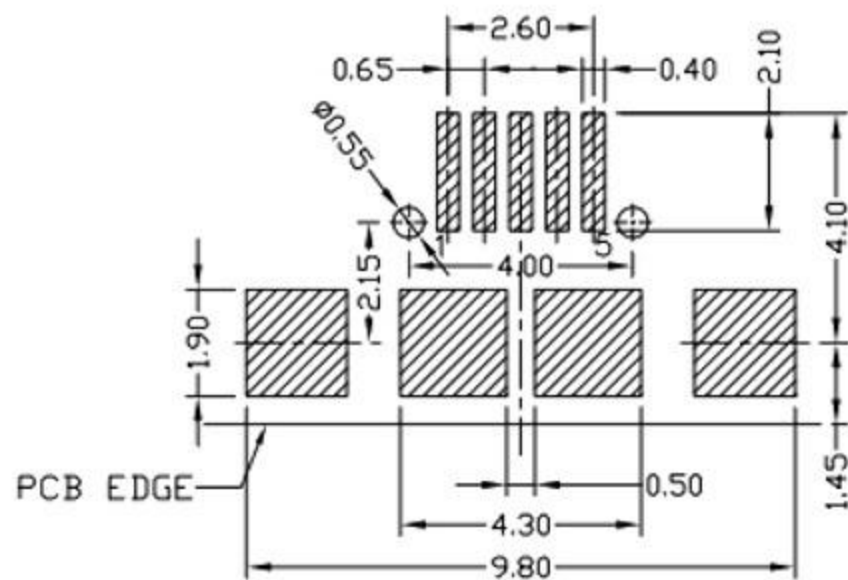
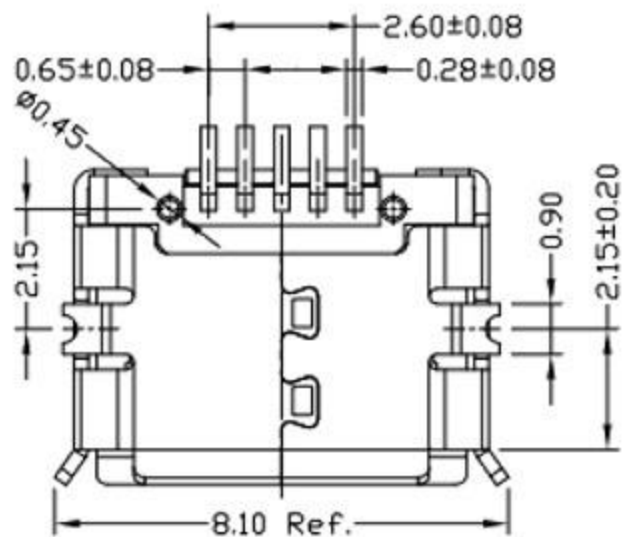
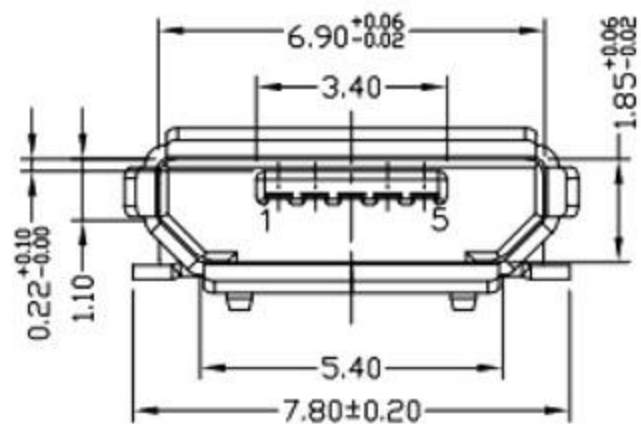
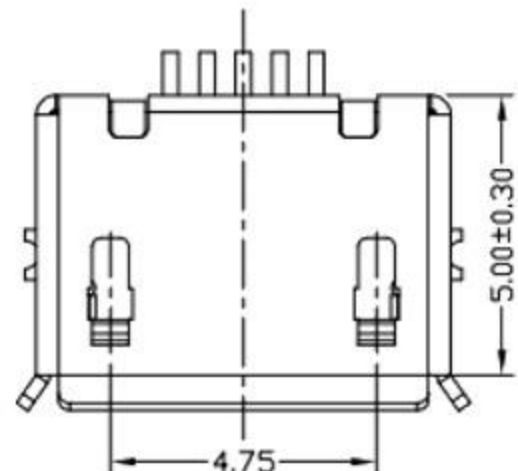
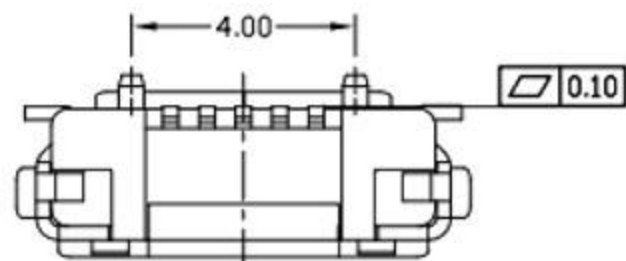

RECOMMENDED PCB LAYOUT

NOTES:

1. ELECTRICAL:

- 1) VOLTAGE CURRENT RATING: PIN1&5 1.8AMP MAX / PIN2&3&4 1AMP MAX. ,30V AC;
- 2) INSULATION RESISTANCE: 100MΩ MIN;
- 3) CONTACT RESISTANCE: 30mΩ MAX;
- 4) WITHSTANDING VOLTAGE: 100V AC; FOR 1 MIN.
- 5) OPERATING TEMPERATURE: -30°C TO +80°C.

2. Mechanical:

- 1) Mating Force: 35N MAX
- 2) Unmating Force: 10N MIN.

3. DIMENSIONS MARKED "▼" TO BE CHECKED BY Q.C & IPQC.

4. PART NO.

1: Au 1U*	W: WHITE
6: Au 30U*	B: BLACK
T: TIN	1: PBT
N: NICKEL	2: PA6T
	3: PA9T
	4: LCP

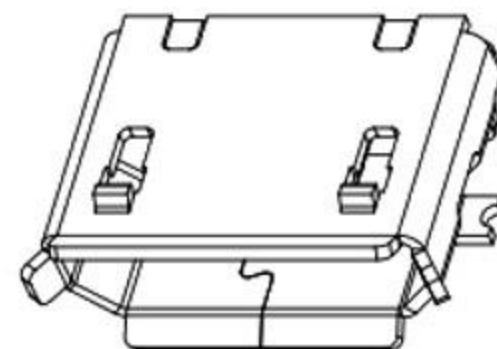
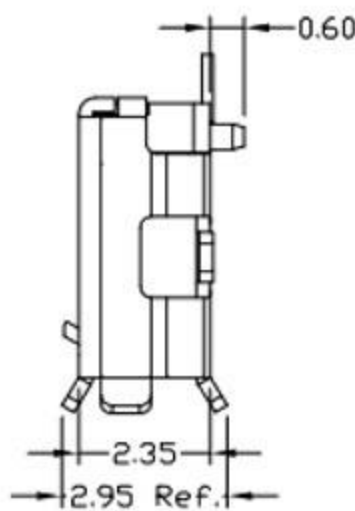

⑤	MID PLATE	1	STAINLESS STEEL	Au . PLATING.	T=0.15mm
④	SHELL	1	STAINLESS STEEL	Au . PLATING.	T=0.30mm
③	TERMINAL-B	1	TABLE 2:	TABLE 2:	T=0.12mm
②	TERMINAL-A	1	TABLE 2:	TABLE 2:	T=0.12mm
①	INSULATOR	1	HIGH TEMP	Black	

NO.	PART NAME	QTY	MATERIAL	DESCRIPTION	REMARK
-----	-----------	-----	----------	-------------	--------

UNLESS OTHERWISE, GENERAL TOLERANCE:
 X.xxx ±0.10
 X.xx ±0.20
 X.x ±0.30
 X. ±0.38
 ANGULAR:
 X.xx ±1°
 X.x ±3°
 X. ±5°

廣東科斯達電子科技有限公司

TITLE: USB connector	P/N: Detail See PART NO. LIST
MODEL:	DRAW NO.:
THIRD ANGLE PROJECTION	UNIT: mm
SCALE: 1:1	SIZE: A4
SHEET: 1/1	

JH2016-080	X2	隨工程图上升版本次	2016.06.15	陈少兵	DESIGN	陈少兵	2016.06.15
JH2016-071	X1	新增规格	2016.06.10	陈少兵	CHECK	郑小伟	2016.06.15
20151224001	X	NEW DRAWING	2016.05.05	陈少兵	APPROVAL	吕海涛	2016.06.15
ECN NO.	REV.	DESCRIPTION	DATE	CHANGE			