

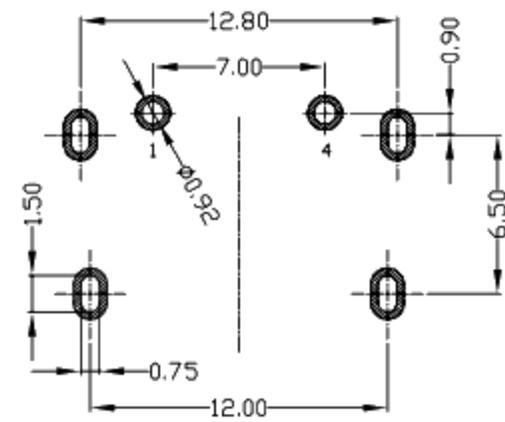

RoHS
Compliant
2002/95/EC

| REV | LTR | DESCRIPTION | DATE | REVISER | APPD |
|-----|-----|-------------|------|---------|------|
| | | | | | |

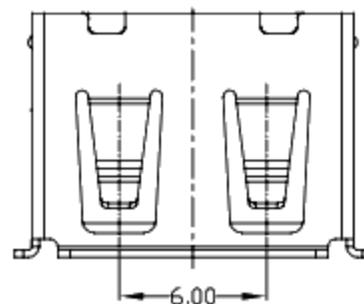

RECOMMENDED PCB LAYOUT

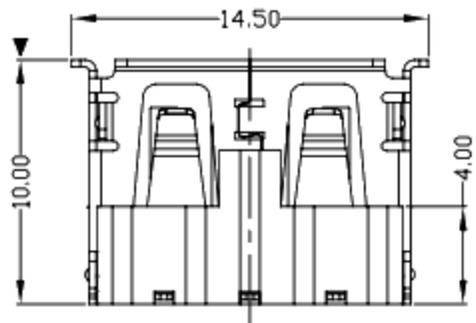
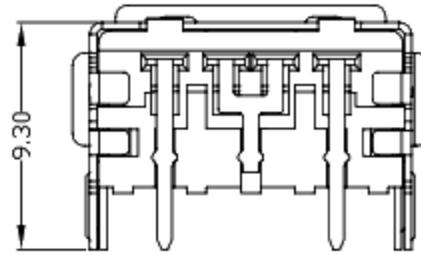
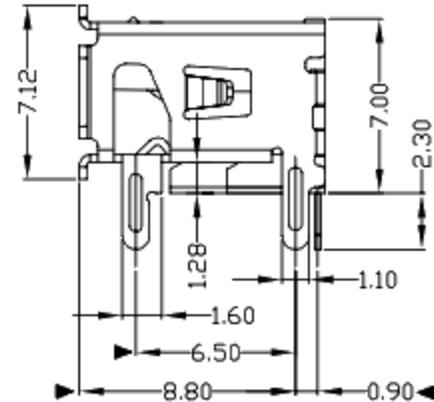
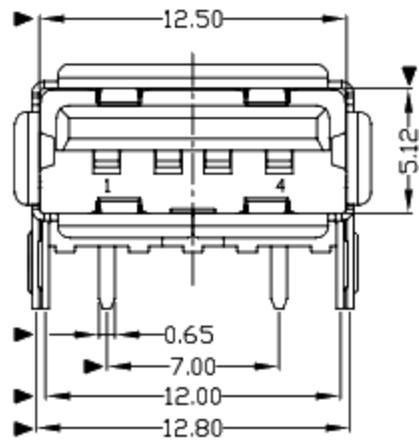

NOTES:

- ELECTRICAL:
 - VOLTAGE CURRENT RATING: 2AMP, 30V AC;
 - INSULATION RESISTANCE: 1000MΩ, MIN;
 - CONTACT RESISTANCE: 30mΩ MAX;
 - WITHSTANDING VOLTAGE: 500V AC;
 - OPERATING TEMPERATURE: -55°C TO +85°C.
- Mechanical:
 - Mating Force: 35N MAX
 - Unmating Force: 10N MIN.
- NOTE: 1. DIMENSIONS MARKED '▼' TO BE CHECKED BY Q.C & IPQC.

4. PART NO.

| | |
|----------|---------|
| 1Au 1U* | W/WHITE |
| 6Au 30U* | B/BLACK |
| | 1/PBT |
| | 2/PA6T |
| | 3/PA9T |
| | 4/LCP |

Bill of materials:

| NO | PARTS | MATERIAL | QTY | FINISHING |
|----|----------|-------------------|-----|-----------------|
| 3 | HOUSING | PBT+30%GF | 1 | UL94V-0 |
| 2 | SHELL | COPPER ALLOY/SPCC | 1 | PLATED NICKEL |
| 1 | TERMINAL | COPPER ALLOY | 4 | PLATED GOLD/TIN |

| UNITS | mm |
|------------|---------|
| X. ±0.35 | X.* ±2' |
| .X ±0.30 | .X* ±1' |
| .XX ±0.25 | .XX* |
| .XXX ±0.15 | .XXX* |

THESE DRAWINGS AND SPECIFICATIONS ARE THE PROPERTY OF ACCURATE INNOTECH INC AND SHALL NOT BE REPRODUCED, COPIED OR USED IN ANY MANNER WITHOUT THE PRIOR WRITTEN CONSENT OF ACCURATE INNOTECH INC.

| | |
|----------|--------|
| SEE NOTE | MAT'L |
| SEE NOTE | FINISH |
| SEE NOTE | Q'TY |

廣東科斯達電子科技有限公司

TITLE: USB AF DTP 90度 10.0 (3線路2P) PART NO.:

DR: gan 2013/5/9 DWG NO.:

CHKD: gan 2013/5/9

APPD:

| | | | |
|-------|-------|------|----------|
| SCALE | SHEET | REV. | CUSTOMER |
| 1:1 | 1/1 | B | DRAWING |