

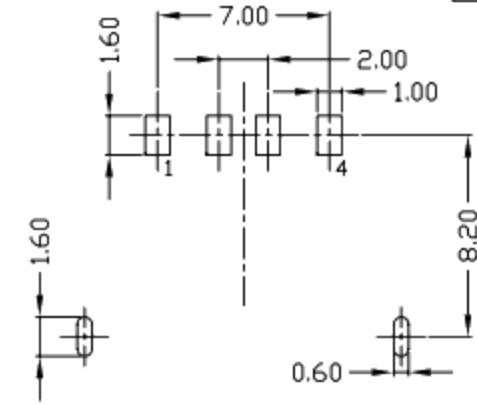

RoHS
Compliant
2002/95/EC

REV.	ECN.	NO.	APPD.

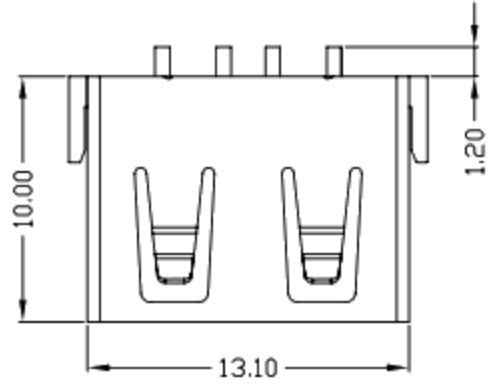

RECOMMENDED PCB LAYOUT

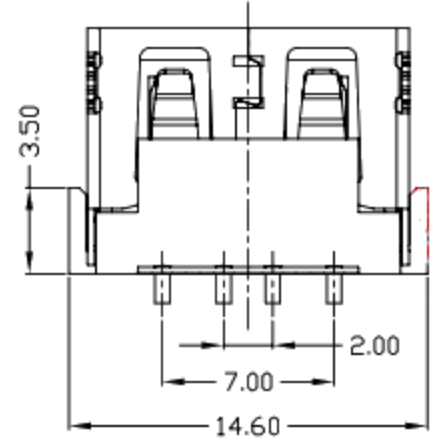
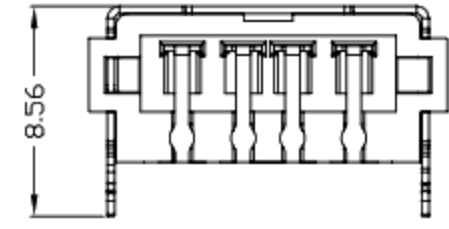
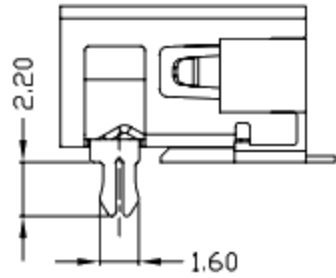
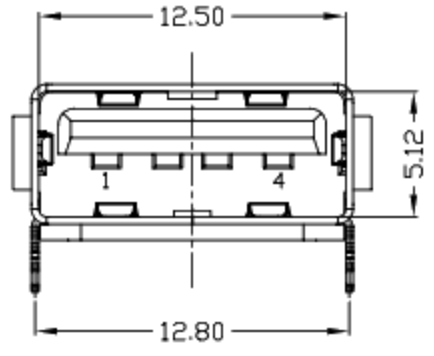
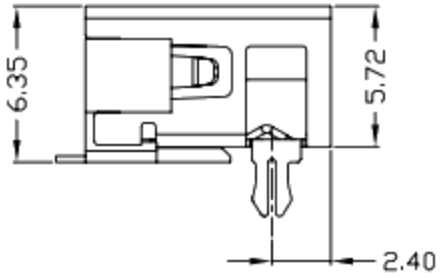

- NOTES:**
- ELECTRICAL:**
 - VOLTAGE CURRENT RATING: 2AMP, 30V AC;
 - INSULATION RESISTANCE: 1000MΩMIN;
 - CONTACT RESISTANCE: 30mΩMAX;
 - WITHSTANDING VOLTAGE: 500V AC;
 - OPERATING TEMPERATURE: -55°C TO +85°C.
 - Mechanical:**
 - Mating Force: 35N MAX
 - Unmating Force: 10N MIN.
 - DIMENSIONS MARKED "▼" TO BE CHECKED BY Q.C & IPQC.**

4. PART NO.
- 1Au 1U*
6Au 30U*
- W/WHITE
B/BLACK
- 1PBT
2PA6T
3PA9T
4LCP

Bill of materials:

NO	PARTS	MATERIAL	QTY	FINISHING
3	HOUSING	LCP+30%GF	1	UL94V-0
2	SHELL	COPPER ALLOY	1	PLATED NICKEL
1	TERMINAL	COPPER ALLOY	4	PLATED GOLD/TIN

X. ±0.35	X.* ±2*	UNITS	mm
.X ±0.3	.X* ±1*	MAT'L	SEE NOTE
.XX ±0.25	.XX*	FINISH	SEE NOTE
.XXX ±0.15	.XXX*	Q'TY	

廣東科斯達電子科技有限公司

TITLE: USB AF SWITCH 0 无卷边 外壳两前脚

PART NO.:

DR: gan 2016/9/20

DWG NO.:

CHKD: gan 2016/9/20

APPD:

SCALE	SHEET	REV.	CUSTOMER DRAWING
1:1	1/1	B	

THESE DRAWINGS AND SPECIFICATIONS ARE THE PROPERTY OF ACCURATE INNOTECH INC AND SHALL NOT BE REPRODUCED, COPIED OR USED IN ANY MANNER WITHOUT THE PRIOR WRITTEN CONSENT OF ACCURATE INNOTECH INC.

