

RoHS Compliant

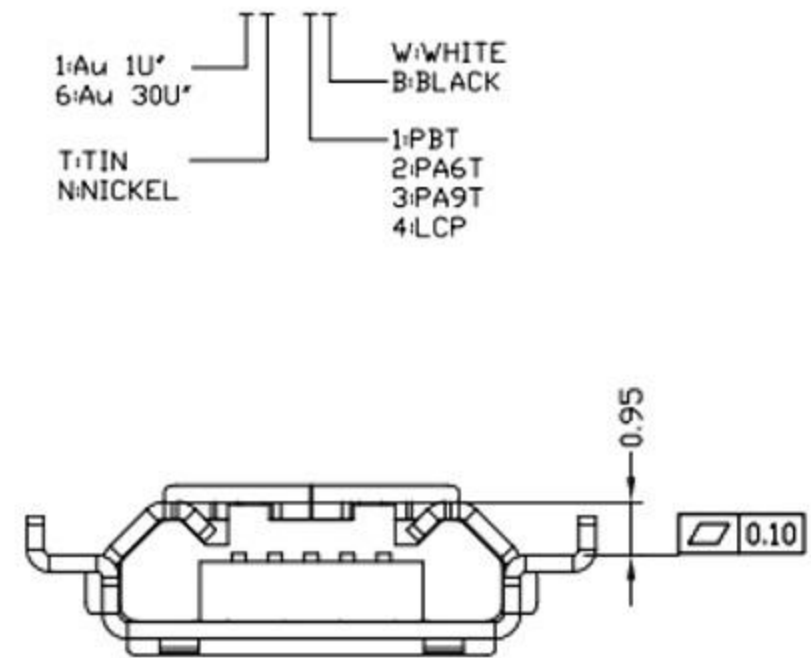
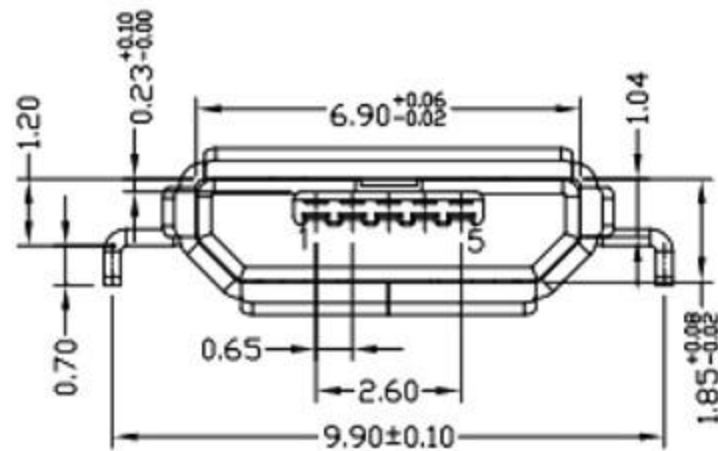
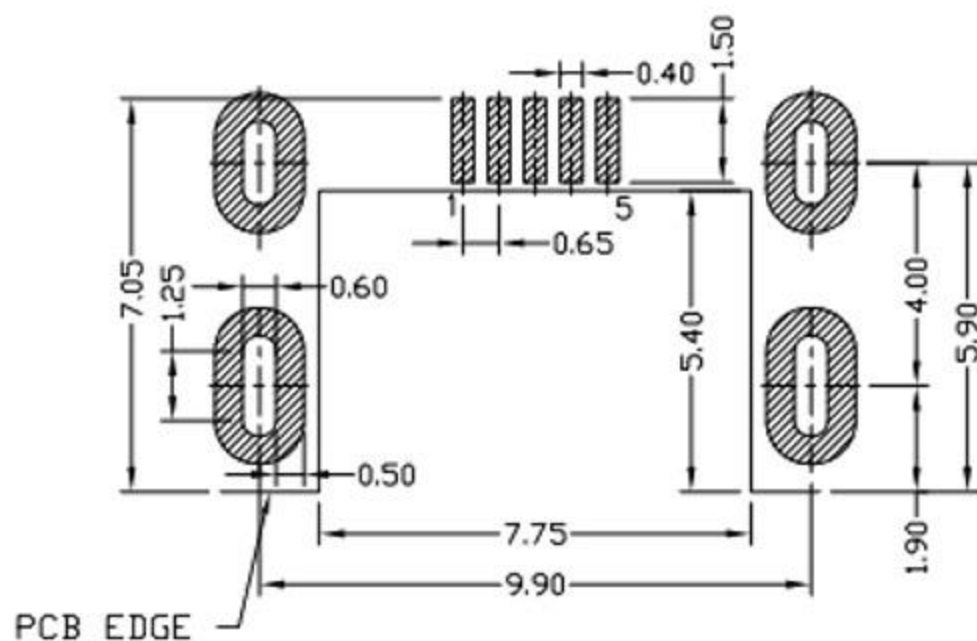
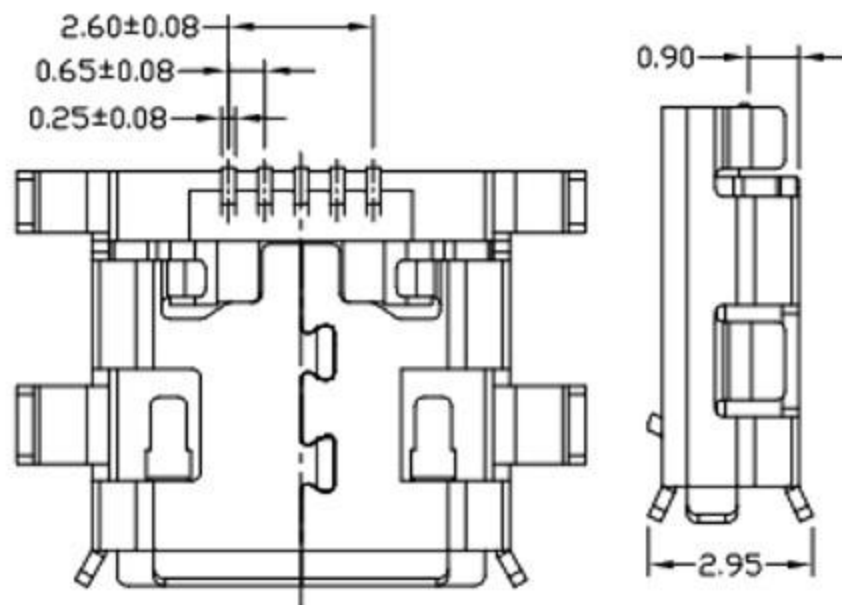
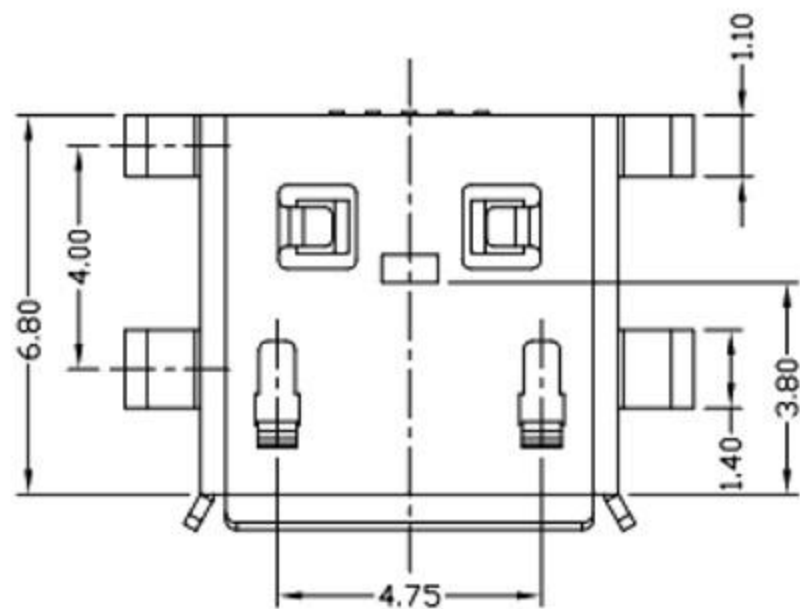

NOTES:

1.ELECTRICAL:

- 1)VOLTAGE CURRENT RATING:PIN1&5 1.8AMP MAX / PIN2&3&4 1AMP MAX. ,30V AC;
- 2)INSULATION RESISTANCE: 100MΩ MIN;
- 3)CONTACT RESISTANCE: 30mΩ MAX;
- 4)WITHSTANDING VOLTAGE: 100V AC; FOR 1 MIN.
- 5)OPERATING TEMPERATURE:-30°C TO +80°C.

2.Mechanical:

- 1)Mating Force: 35N MAX
- 2)Unmating Force: 10N MIN.

3.DIMENSIONS MARKED "▼" TO BE CHECKED BY Q.C & IPQC.

4.PART NO.

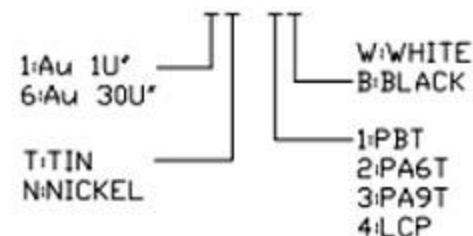

RECOMMENDED PCB LAYOUT
TOLERANCE:±0.03

NO.	PART NAME	QTY	MATERIAL	DESCRIPTION	REMARK
⑤	MID PLATE	1	STAINLESS STEEL	Au . PLATING.	T=0.15mm
④	SHELL	1	STAINLESS STEEL	Au . PLATING.	T=0.30mm
③	TERMINAL-B	1	TABLE 2:	TABLE 2:	T=0.12mm
②	TERMINAL-A	1	TABLE 2:	TABLE 2:	T=0.12mm
①	INSULATOR	1	HIGH TEMP	Black	

UNLESS OTHERWISE,
GENERAL TOLERANCE:

- X.xxx ±0.10
- X.xx ±0.20
- X.x ±0.30
- X. ±0.38

ANGULAR:

- X.xx ±1°
- X.x ±3°
- X. ±5°

廣東科斯達電子科技有限公司

TITLE: USB connector
P/N: Detail See PART NO. LIST
MODEL:
DRAW NO.:

THIRD ANGLE PROJECTION	UNIT: mm	SCALE: 1:1	SIZE: A4	SHEET: 1/1
------------------------	----------	------------	----------	------------

ECN NO.	REV.	DESCRIPTION	DATE	CHANGE	APPROVAL	DATE
JH2016-080	X2	隨工程圖上升版本次	2016.06.15	陈少兵	DESIGN	2016.06.15
JH2016-071	X1	新增规格	2016.06.10	陈少兵	CHECK	2016.06.15
20151224001	X	NEW DRAWING	2016.05.05	陈少兵	APPROVAL	2016.06.15