

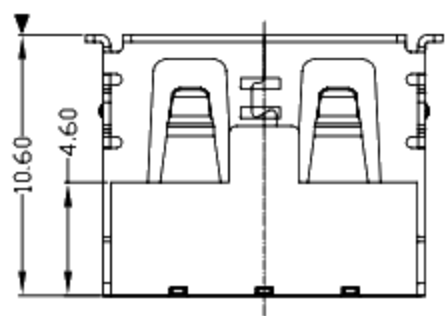

RoHS
Compliant
2002/95/EC

REV	LTR	DESCRIPTION	DATE	REVISER	APPD

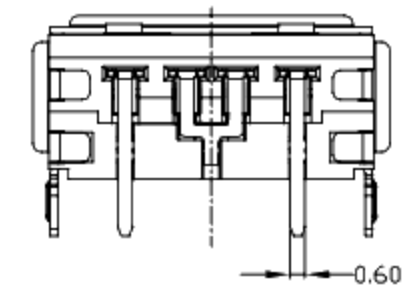
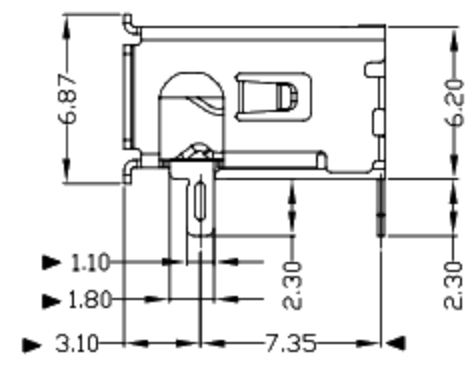
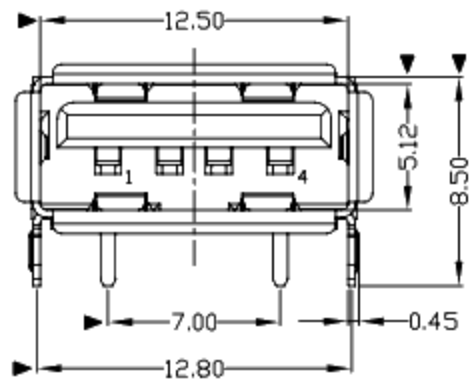
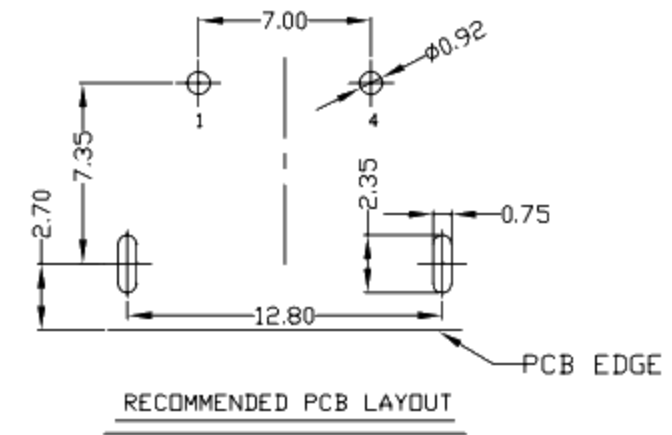
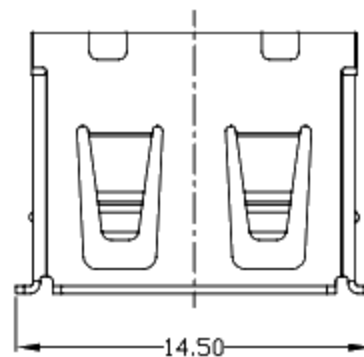

NOTES:

- ELECTRICAL:
 - VOLTAGE CURRENT RATING: 2AMP, 30V AC;
 - INSULATION RESISTANCE: 1000MΩ, MIN;
 - CONTACT RESISTANCE: 30mΩ MAX;
 - WITHSTANDING VOLTAGE: 500V AC;
 - OPERATING TEMPERATURE: -55°C TO +85°C.
- Mechanical:
 - Mating Force: 35N MAX
 - Unmating Force: 10N MIN.
- NOTE: 1. DIMENSIONS MARKED "▼" TO BE CHECKED BY Q.C & IPQC.

4. PART NO.

1-Au 1U'	W/WHITE
6-Au 30U'	B/BLACK
	1/PBT
	2/PA6T
	3/PA9T
	4/LCP

Bill of materials:

NO	PARTS	MATERIAL	QTY	FINISHING
3	HOUSING	PBT+30%GF	1	UL94V-0
2	SHELL	COPPER ALLOY/SPCC	1	PLATED NICKEL
1	TERMINAL	COPPER ALLOY	4	PLATED GOLD/TIN

	X. ±0.35	X.' ±2'	UNITS
	.X ±0.30	.X' ±1'	mm
	.XX ±0.25	.XX'	MAT'L
	.XXX ±0.15	.XXX'	SEE NOTE
			FINISH
			SEE NOTE
			Q'TY

THESE DRAWINGS AND SPECIFICATIONS ARE THE PROPERTY OF ACCURATE INNOTECH INC AND SHALL NOT BE REPRODUCED, COPIED OR USED IN ANY MANNER WITHOUT THE PRIOR WRITTEN CONSENT OF ACCURATE INNOTECH INC.

廣東科斯達電子科技有限公司

TITLE:	FSB AF DIP 90度 10.6 (3線2P)		
PART NO.:			
DR:	gan 2013/5/9	DWG NO.:	
CHKD:	gan 2013/5/9	SCALE	SHEET
APPD:		1:1	1/1
		REV.	CUSTOMER DRAWING
		B	