

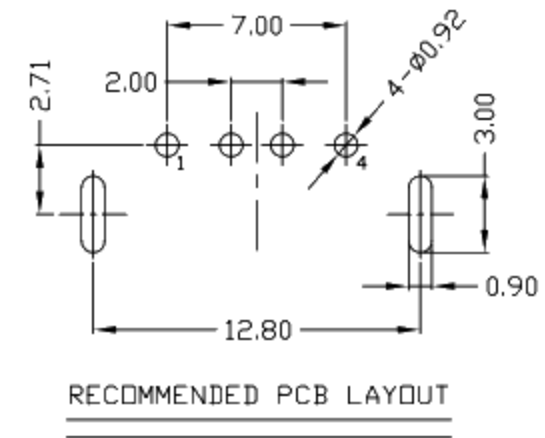

RoHS
Compliant
2002/95/EC

REV.	ECN.	NO.	APPD.

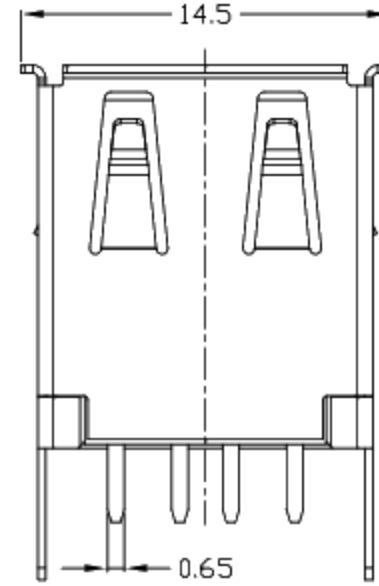
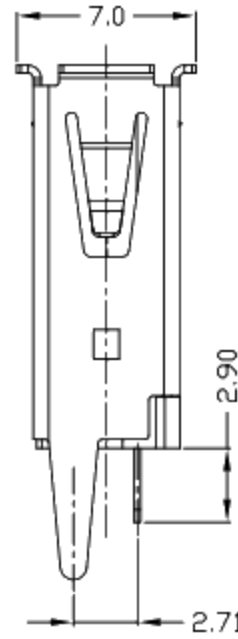
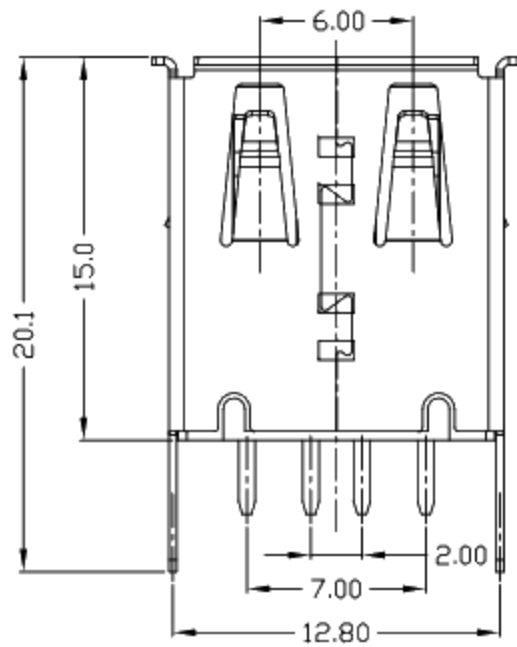
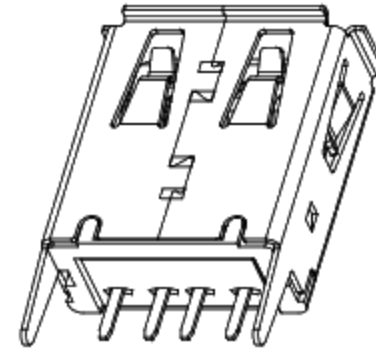
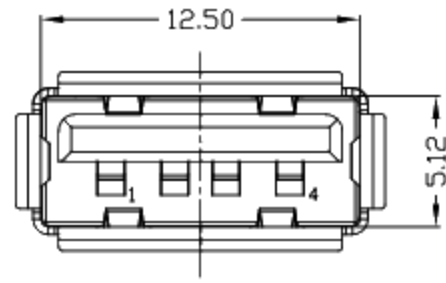

NOTES:

- ELECTRICAL:
 - VOLTAGE CURRENT RATING: 2AMP, 30V AC;
 - INSULATION RESISTANCE: 1000MΩMIN;
 - CONTACT RESISTANCE: 30mΩMAX;
 - WITHSTANDING VOLTAGE: 500V AC;
 - OPERATING TEMPERATURE: -55°C TO +85°C.
- Mechanical:
 - Mating Force: 35N MAX
 - Unmating Force: 10N MIN.
- DIMENSIONS MARKED "▼" TO BE CHECKED BY Q.C & IPQC.

4. PART NO.

1-Au 1U*
6-Au 30U*

W: WHITE
B: BLACK
1: PBT
2: PA6T
3: PA9T
4: LCP

Bill of materials:

NO	PARTS	MATERIAL	QTY	FINISHING	UNITS	mm	廣東科斯達電子科技有限公司				
4	COVER	PBT+30%GF	1	UL94V-0	X. ±0.35	X.* ±2'	MAT'L	TITLE: USB AF DIP 180° 全包围脚 卷边(13.0)		PART NO.:	
3	HOUSING	PBT+30%GF	1	UL94V-0	.X ±0.3	.X' ±1'	SEE NOTE	DR: gan 2016/9/20		DWG NO.:	
2	SHELL	COPPER ALLOY/SPCC	1	PLATED NICKEL	.XX ±0.25	.XX'	FINISH	CHKD: gan 2016/9/20		SCALE SHEET REV. CUSTOMER	
1	TERMINAL	COPPER ALLOY	4	PLATED GOLD/TIN	.XXX ±0.15	.XXX'	SEE NOTE	APPD:		1:1 1/1 B DRAWING	
THESE DRAWINGS AND SPECIFICATIONS ARE THE PROPERTY OF ACCURATE INNOTECH INC. AND SHALL NOT BE REPRODUCED, COPIED OR USED IN ANY MANNER WITHOUT THE PRIOR WRITTEN CONSENT OF ACCURATE INNOTECH INC.					Q'TY						